



BRITISH VIRGIN ISLANDS AIRPORTS AUTHORITY



CONSTRUCTION OF THE FIRE HALL  
AT  
THE AUGUSTE GEORGE INTERNATIONAL AIRPORT



*Table Of Contents*

1.	Introduction	5
1.1	Project Objectives	5
1.2	Specific Objectives	6
1.3	BVIAA Input	6
1.4	Project Scope	7
1.5	Cost of Tendering	7
1.6	Site Visit	7
1.7	Content of Tender Documents	8
1.8	Clarification of Tender Documents	8
1.9	Language of Tender	9
1.10	Amendment of Tender Documents	9
1.11	Alterations to Tender Documents	9
1.12	Documents Comprising the Tender	9
1.13	Tender Prices	11
1.14	Currencies of Tender and Payment	11
1.15	Tender Validity Period	11
1.16	Variant Solutions	12
1.17	Submission of Tenders	12
1.18	Late Tenders	12
1.19	Modification and Withdrawal of Tenders	13
1.20	Tender Opening	13
1.21	Process to be Confidential	13
1.22	Clarification of Tenders	14
1.23	Determination of Responsiveness	14
1.24	Correction of Errors	15
1.25	Evaluation and Comparison of Tenders	15
1.26	Award Criteria	16
1.27	Employer's Right to Accept or Reject Any or All Tenders	16
1.28	Notification of Award	17
1.29.	Signing of Agreement	17
1.30	Performance Security	18
2.	PROPOSAL AND EVALUATION	19
2.1	Submission Requirements	19
2.2	Delivery	19
2.3	Technical Proposal	20



## AUGUSTE GEORGE INTERNATIONAL AIRPORT FIRE HALL.

2.4	Financial Proposal	20
2.5	Evaluation Criteria	20
2.6	Reporting System	22
2.7	Scheduling of Works	23
2.8	Employer Inputs	23
2.9	Variation and Change Management	23
2.10	Communication	23
2.11	Contractor's Roles and Responsibilities	24
3.	Payment, Rebates and Invoices	24
3.1	Introduction	24
3.2	Payments for Contractor's Services	25
3.3	Submission of Invoices for Additional Services	25
3.4	Submission of Invoices	25
3.5	Netting	25
3.6	Payment Process	26
4.	TENDER DATA SHEET (TDS)	27
5.	FORM OF TENDER	28
6.	CERTIFICATE OF VISIT TO SITE	31
7.	STATEMENT OF EXPERIENCE ON SIMILAR PROJECTS	32
8.	CURRENT CONTRACT COMMITMENTS/ WORK IN PROGRESS	33
9.	FORM OF AGREEMENT	34
	Parties	36
	Background	36
1	Definitions and interpretation	36
2	Commencement and duration of Project	41
3	Provision of Equipment and Services	41
4	Outside interests, conflicts and protection of Authority's business interests	42
5	Contract Price and payment	43
6	Expenses	44
7	Tax liability, national health insurance and social security contributions	44
8	No employment or benefits	44
9	Liability, indemnity and insurance	45
10	Confidential Information	45



## AUGUSTE GEORGE INTERNATIONAL AIRPORT FIRE HALL.

11	Risk and title to the Equipment	46
12	Intellectual property	46
13	Data protection and monitoring	47
14	Anti-bribery and corruption	48
15	Obligations of the Authority	48
16	Public statements and announcements	48
17	Breach, suspension and termination	48
18	Obligations on termination	50
19	Restrictions on assignment/sub-contracting	51
20	Notices	51
21	Entire agreement	51
22	Further assurance	51
23	Variation	51
24	Set off	51
25	No partnership or agency	52
26	Remedies and waiver	52
27	Equitable relief	52
28	Severability	52
29	Counterparts	52
30	Legal expenses	52
31	Resolution of disputes	52
32	Governing law	53
	The Schedule	54



REQUEST FOR PROPOSAL  
CONSTRUCTION FIRE HALL - AUGUSTE GEORGE INTERNATIONAL AIRPORT

## 1. Introduction

- 1.0.1 The BVI Airports Authority Ltd. (BVIAA) is a state-owned entity responsible for managing, operating, and maintaining all three airports within the Territory. The primary mission of the BVIAA is to ensure the safe, secure, and timely movement of passengers through its airports
- 1.0.2 Through this Request for Proposal ("RFP"), the BVIAA is seeking submissions from qualified and experienced contractors specialising in the construction of fire hall facilities. This RFP specifically targets the construction of a dedicated fire hall facility at Auguste George International Airport, Anegada
- 1.0.3 Auguste George International Airport serves as the primary aviation gateway to Anegada, supporting commercial operations and providing essential services to the island community. As part of the BVIAA's ongoing infrastructure development programme, the Authority is investing in enhanced facilities to support airport operations and ensure continued compliance with aviation safety standards
- 1.0.4 The BVIAA has procured a metal building structure for this purpose, which is currently stored onsite in disassembled condition. The fire hall facility will provide dedicated accommodation for the airport's fire appliance and fire service personnel. This purpose-built facility will enhance operational efficiency, protect valuable assets, and ensure that fire service operations are conducted from appropriate, professionally designed premises.
- 1.0.5 This project represents an important investment in the airport's operational infrastructure and demonstrates the BVIAA's commitment to maintaining the highest standards of safety and service delivery across all facilities within the Territory.

### 1.1 Project Objectives

- 1.1.1 The primary objective of this project is to construct a fire hall facility that will serve Auguste George International Airport for decades to come. The facility must meet all regulatory

requirements whilst providing a functional, durable, and cost-effective solution for the airport's fire service operations.

## 1.2 Specific Objectives

1.2.1 The specific objectives of the system are:

- Erection of the existing metal building structure currently stored onsite to house the airport's fire appliance;
- Construction of appropriate foundation and base works to support the metal building structure in accordance with structural and engineering requirements.
- Rough-in of the electrical and plumbing;
- Installation of plumbing and drainage systems, including water supply, sanitary facilities, and site drainage.
- Completion of all site works, including access roads, hard-standing areas for vehicle manoeuvring, and perimeter drainage;
- Application of internal and external finishes to meet operational requirements and professional standards;

## 1.3 BVIAA Input

1.3.1 The BVI Airports Authority Ltd (BVIAA) will provide the following support and resources to facilitate the successful execution of the consultancy:

- **Access to Site:** Full access to the Auguste George International Airport proposed fire hall site.
- **Relevant Documentation:** Access to all available and relevant documents, reports, data, and airport plans necessary for the execution of the consultancy.
- **Operational Guidelines:** Provision of current Airport Operations Policies and Procedures.
- **Counterpart Personnel:** Designated BVIAA staff to support the project, and sign off on key deliverables at specified milestones.
- **Project Financing:** Full financing of the consultancy, to be provided through BVIAA's allocated funds.

## 1.4 Project Scope

1.4.1 The proposed works comprise of providing all plant, labour, equipment and materials and performing all operations in connection with the following:

1. Site preparation and foundation works
2. Erection of building structure as per approved drawings
3. Installation of doors, windows, and hardware
4. Rough-in of electrical and plumbing.
5. Interior finishes, including flooring, wall finishes, and painting
6. Installation of fire apparatus bay doors
7. Construction of the appliance floor with required drainage
8. Installation of a septic tank
9. External works, including apron, parking, and site drainage

## 1.5 Cost of Tendering

1.5.1 The Tenderer shall bear all costs associated with the preparation and submission of his tender. The Employer will not accept responsibility or liability for these costs whatsoever, regardless of the outcome of the tendering process.

## 1.6 Site Visit

1.6.1 The Tenderer and any of his personnel or agents will be granted permission by the Employer to enter unto the premises and lands for the purpose of inspection, but only upon the express conditions that the Tenderer and his personnel or agents, will release and indemnify the Employer and his personnel and agents from and against all liability in respect thereof and will be responsible for personal injury (whether fatal or otherwise), loss of or damage to property and any other loss, damage, costs and expenses however caused, which, but for the exercise of such permission would not have arisen.

1.6.2 The Tenderer and any of his personnel or agents are invited to a virtual pre-tender meeting at the date and time included in the TDS. Tenderers will be provided with credentials including the access code and password prior to the meeting.



- 1.6.3 The purpose of the pre-tender meeting will be to clarify issues or concerns and to answer questions on any matter that may be raised at that stage.

## 1.7 Content of Tender Documents

- 1.7.1 The documents issued for the purpose of this Invitation to Tender are detailed below, together with any Addenda thereto issued in accordance with **Clause 1.10**:
- i. Instructions to Tenderers
  - ii. Tender Data Sheet (TDS)
  - iii. Form of Tender, Appendix -A, Schedules
  - iv. Certification of Visit to Site (if necessary)
  - v. Drawings and Specifications
  - vi. Form of Agreement
  - vii. General Conditions of Contract
  - viii. Particular Conditions
  - ix. Form of Performance Security
  - x. Bill of Quantities
- 1.7.2 The Tenderer shall carefully examine all documents. Failure to comply with the tender submission requirements will be at the Tenderer's own risk.
- 1.7.3 Tenders which are not substantially responsive to the requirements of the tender documents and/or who which fail to meet the technical requirements will be rejected.

## 1.8 Clarification of Tender Documents

- 1.8.1 Tenderers requiring clarification of the tender documents may notify the Employer in writing (including electronic mail) at the address indicated in the TDS no later than the time stated in the TDS.
- 1.8.2 The Employer will respond in writing (including electronic mail) to any request for clarification that he/she receives earlier than the time provided in the TDS.
- 1.8.3 Written copies of the response, including a description of the inquiry but without identifying its source, will be sent to all Tenderers.

## **1.9 Language of Tender**

- 1.9.1 The tender language is English. If permitted in the TDS, supporting documents and printed literature furnished by the Tenderer may be in another language provided they are accompanied by an appropriate translation of pertinent passages into English. In case of conflict between the original document and English translation, the English translation shall prevail.

## **1.10 Amendment of Tender Documents**

- 1.10.1 At any time prior to the deadline for submission of tenders, the Employer may, for any reason, whether at his own initiative or in response to a request for clarification by a prospective Tenderer, modify the tender documents by the issue of an Addendum.
- 1.10.2 Any Addendum will be sent in writing (including electronic mail) to all prospective Tenderers and will be binding upon them. Prospective Tenderers shall promptly acknowledge receipt thereof to the Employer.
- 1.10.3 In order to afford tenderers reasonable time to take any addendum into account when preparing their tenders, the employer may, at his discretion, extend the deadline for the submission of tenders.

## **1.11 Alterations to Tender Documents**

- 1.11.1 Tenderers may not alter any of the documents. Any modification, which a Tenderer may think is necessary, should be detailed and forwarded to the Employer no later than the time stated in the TDS prior to the deadline for the submission of tenders. The Employer is not obligated to accept a request for modification of the tender documents.

## **1.12 Documents Comprising the Tender**

- 1.12.1 Tenders shall be submitted in strict compliance with all the requirements as set out in this Invitation to Tender.
- 1.12.2 The Tender to be prepared by the Tenderer shall comprise the following:



## AUGUSTE GEORGE INTERNATIONAL AIRPORT FIRE HALL.

- I. A completed Form of Tender in accordance with Section 5. This form must be completed without alteration to its wording or format, and no substitutes shall be accepted except for the one provided;
- II. A comprehensive cost proposal along with financing terms and conditions
- III. A list of projects undertaken by the Tenderer within the past ten (10) years that demonstrate the Tenderer's experience in delivering similar projects in the form included in Section 7;
- IV. A list of Current Contract Commitments/Work in Progress in the form included in Section 8;
- V. An Organizational Chart showing management structure including contact details of the key members of the organization that are to be involved with this tender, including the proposed project manager and contractor's representative (on site).
- VI. A detailed Work Programme and Method Statement showing the order in which the various sections of work are to be executed and the rates of progress.
- VII. Tenderers will be required to provide proof that the company or individual is in good standing with respect to taxes, duties, Social Security and National Health Insurance contributions, Company Registration, or payments due to the Government of the Virgin Islands. Certificates of Good Standing must be obtained from the Director of Social Security Board and National Health Insurance, and the Commissioner of Inland Revenue;
- VIII. Tenderers registered as companies in the British Virgin Islands are required to submit a Certificate of Good Standing from the Commercial Registry.

A Special Certificate is required from the Company Registry at the Financial Services Commission, indicating that all fees due are paid and that the company is in good standing. This certificate should be dated no later than six (6) months prior to the date of the tender opening.

- 1.12.3 Tenderers operating in the British Virgin Islands are required to submit a Trade License (valid for 2026).



- 1.12.4 Companies not registered or operating in the British Virgin Islands are required to provide a valid business license or equivalency as proof of authorization to operate a business in the area of the required expertise in its jurisdiction of operation.
- 1.12.5 Any other materials are required to be completed and submitted in accordance with the Instructions to Tenderers embodied in these Tender Documents. The Forms, in these Tender Document shall be used without exception.

### **1.13 Tender Prices**

- 1.13.1 The Tenderer accepts that any and all omissions or errors in his pricing are his responsibility.
- 1.13.2 The Tenderer accepts full responsibility for the accuracy of all prices provided in his tender and agrees that these prices include full provision for any increase in his costs for whatsoever reason over the period of time from his submission of tender to completion of the project and settlement of the final account.
- 1.13.3 The Tenderer's prices shall take account of all provisions for the performance of his work, including, but not necessarily limited to, all costs fees and currency exchange rates, etc.

### **1.14 Currencies of Tender and Payment**

- 1.14.1 The Tender Price and any subsequent payments shall be entirely in US Dollars.

### **1.15 Tender Validity Period**

- 1.15.1 Tenders shall remain valid and open for acceptance for the period stated in the TDS after the date of tender opening prescribed in **Clause 1.20**.
- 1.15.2 In exceptional circumstances, prior to expiry of the tender validity period, an extension may be requested to the tender validity period. The request and response thereto shall be by writing (including electronic mail).



## 1.16 Variant Solutions

- 1.16.1 Tenderers shall submit offers which comply fully with the requirements of the Tender Document.
- 1.16.2 If permitted in the TDS, tenderers wishing to offer unsolicited technical alternatives to the requirements of the Tender Document must first price the basic technical requirements of the tender documents and shall further provide all information necessary for a complete evaluation of the alternative by the Employer, including design calculations, technical specifications, breakdown of prices, proposed construction methodology and other relevant details. Only the technical alternatives, if any, of the lowest evaluated Tender on the basic technical requirements shall be considered by the Employer.

## 1.17 Submission of Tenders

- 1.17.1 Electronic submissions of the Tenders in a non-editable format and not exceeding 15 MB must be received by the Employer at the email address [rfp@bviaa.com](mailto:rfp@bviaa.com) as specified in **Clause 1.12** no later than the date and time provided in the TDS. The filename and the email subject must bear the Applicant's name and "RFP for the construction of a Fire Hall - Auguste George International Airport.
- 1.17.2 When submitting a Tender, the Tenderer may request that a Certificate of Submittal be signed by a representative of the Procurement Team.
- 1.17.3 The Employer may, at his discretion, extend the deadline for submission of tenders by issuing an amendment in accordance with **Clause 1.10.3**, in which case all rights and obligations of the Employer and the Tenderer previously subject to the original deadline shall thereafter be subject to the new deadline as extended.

## 1.18 Late Tenders

- 1.18.1 Late Tenders are not permitted. Any tender received by the Employer after the deadline for Submission of Tender in accordance with **Clause 1.17** shall be deemed never to have been received and will be returned unopened to the Tenderer.



## 1.19 Modification and Withdrawal of Tenders

- 1.19.1 A Tenderer may modify or withdraw his tender after Tender Submission, provided that the modification notice, or withdrawal is received in writing by the Employer prior to the prescribed deadline for Submission of Tenders.
- 1.19.2 The Tenderer's modification or notice of withdrawal shall be prepared, sealed, marked and delivered in accordance with the provisions of **Clause 1.19.1** for the submission of tenders, with the inner envelopes marked "MODIFICATION" or "WITHDRAWAL" as appropriate.
- 1.19.3 No tender may be modified subsequent to the deadline for submission of tenders.

## 1.20 Tender Opening

- 1.20.1 The Employer will open the Tenders, including submissions made pursuant to **Clause 1.23**, in the presence of any of the Tenderer's representatives who choose to attend, at the date and time included in the TDS. Tenderers are invited to witness this process in person or via a virtual platform and will be provided with credentials including the access code and password prior to the opening.
- 1.20.2 Tenders for which an acceptable notice of withdrawal has been submitted pursuant to **Clause 1.23** shall not be opened. The Employer will examine Tenders to determine whether they are complete, whether the documents have been properly signed, and whether the Tenders are generally in order.
- 1.20.3 At the Tender opening, the Employer will announce the Tenderer's names, the Tender prices, and written notifications of tender modifications and withdrawals, if any.
- 1.20.4 The Employer shall prepare, for his own records, minutes of the Tender opening, including the information disclosed to those present in accordance with Sub-**Clause 1.25.3**.

## 1.21 Process to be Confidential

- 1.21.1 After the public opening of tenders, information relating to the examination, clarification, evaluation and comparison of tenders

and recommendations concerning the award of contract, shall not be disclosed to Tenderers, or other persons not officially concerned with such process until the award of the Contract to the successful Tenderer has been announced.

- 1.21.2 Any effort by a Tenderer to influence the Employer in the process of examination, clarification, evaluation and comparison of tenders, and in decisions concerning the award of contract, may result in rejection of their Tender.

## 1.22 Clarification of Tenders

- 1.22.1 To assist in the examination, evaluation and comparison of Tenders the Employer may ask Tenderers individually for clarification of their tenders, including breakdowns of unit rates.
- 1.22.2 The request for clarification and the response shall be in writing (including electronic mail).
- 1.22.3 No change in price or substance of the tender shall be sought, offered or permitted except as required to confirm the correction of arithmetic errors discovered by the Employer during the evaluation of the Tender in accordance with **Clause 1.24**

## 1.23 Determination of Responsiveness

- 1.23.1 Prior to the detailed evaluation of tenders, the Employer will determine whether each tender is substantially responsive to the requirements of the tender documents.
- 1.23.2 For the purpose of this Clause, a substantially responsive Tender is one which conforms to all the terms, conditions and specifications of the Tender Documents without material deviation or reservation. A material deviation or reservation is one which affects, in any substantial way, the scope, quality or performance of the Works, or which limits in, any substantial way, the Employer's rights or the Tenderer's obligations under the Contract, the rectification of which would affect unfairly the competitive position of other Tenderers presenting substantially responsive tenders.
- 1.23.3 If a Tender is not substantially responsive to the requirements of the Tender Documents, it will be rejected by the Employer. It may not subsequently be made responsive by the tenderer

correcting or withdrawing the non-conforming deviation or reservation.

## 1.24 Correction of Errors

1.24.1 Tenders determined to be substantially responsive will be checked by the Employer for arithmetic errors in computation and summation. The Employer will correct errors as follows:

1. Where there is a discrepancy between amounts in figures and in words, the amount in words will govern; and,
2. Where there is a discrepancy between the unit rate and the total amount derived from the multiplication of the unit rate and the quantity, the unit rate quoted will govern; unless in the opinion of the Employer there is an obviously gross misplacement of the decimal point in the unit rate, in which event the total amount as quoted will govern and the unit rate will be corrected.

1.24.2 The amount stated in the Form of Tender will be adjusted by the Employer in accordance with the above procedure for correction of errors and, with the concurrence of the Tenderer, shall be considered as binding upon the Tenderer. If the Tenderer does not accept the corrected amount of Tender, his Tender will be rejected.

## 1.25 Evaluation and Comparison of Tenders

1.25.1 The Employer will evaluate and compare only tenders considered to be substantially responsive to the requirements of the Tender Documents, in accordance with **Clause 1.23**.

1.25.2 In evaluating tenders, the Employer will determine for each tender the Evaluated Tender Price by adjusting the Tender Price as follows:

1. Making any corrections or errors pursuant to **Clause 1.24**.
2. Including Day Work priced competitively.
3. Making an appropriate adjustment for any other acceptable quantifiable variations, deviations or alternative offers not reflected in the Tender Price or in the above-mentioned adjustments.



- 1.25.3 The Employer reserves the right to accept or reject any variation, deviation or alternative offer. Variations, deviations, alternative offers and factors which are in excess of the requirements of the Tender Documents or otherwise result in the accrual of unsolicited benefits to the Employer shall not be taken into account in tender evaluation.

## **1.26 Award Criteria**

- 1.26.1 The Employer will award the Contract to the Tenderer whose Tender has been determined to be substantially responsive to the Tender Documents, and who has offered the most advantageous tender pursuant to Clause 1.30, provided further that the Tenderer has, in the opinion of the evaluating committee, clearly demonstrated the capability and resources to carry out the Contract effectively.

## **1.27 Employer's Right to Accept or Reject Any or All Tenders**

- 1.27.1 The Employer reserves the right to accept or reject any or all tenders without giving any reason for such rejection and has the right to reject any non-complying tender that fails to meet any requirement, term or condition set forth in the Tender Documents, as well as relevant laws, rules, and regulations.
- 1.27.2 Any one of the following circumstances, which are not exhaustive, may result in the rejection of the affected tender, or disqualification of concerned Tenderers, and/or other administrative sanction whenever appropriate:
1. False or misleading statements or evidence of fraud;
  2. Failure to furnish signatures or seals when required;
  3. Failure to furnish a completed and signed Form of Tender;
  4. Tenders without adequate Tender Securities;
  5. Collusion among Tenderers for the purpose of fixing Tender Prices or negating competition;
  6. Giving or offering of any illegal compensation to officers, employees and or, agents of BVI Airports Authority connected with the project;
  7. Failure to furnish any information required to be included in the Tender; and
  8. A Tenderer having an unfair competitive advantage or a conflict of interest to the requirements of the Tender or the works to be performed under a contract resulting from this Tender.



- 1.27.3 The Employer does not bind itself to accept the lowest or any tenders and is not obliged to give any reasons for its selection.

## **1.28 Notification of Award**

- 1.28.1 Prior to the expiration of the period of tender validity and contract award, the Purchaser shall send the Notification of Intention to Award (“NOITA”) to the successful Tenderer and all unsuccessful Tenderers, pursuant to section 51 (2) of the Act and Section 37 of the Regulations. The NOITA shall include a statement that the Purchaser shall issue a formal Notification of Award and draft Contract after expiration of the period for filing a challenge and the resolution of any challenges that are submitted. Delivery of the NOITA shall not constitute the formation of a contract between the Purchaser and the successful Tenderer and no legal or equitable rights will be created through the delivery of the NOITA.
- 1.28.2 After such notification, a Tenderer may request a debrief seeking explanations for the grounds on which its Tender was not selected.
- 1.28.3 Whether or not a Tenderer requested a debrief, a Tenderer reserves the right to challenge the results of a procurement only according to the rules and provisions established in Section 27(1) of the Act and 28(1) of the Regulations.
- 1.28.4 In the absence of a challenge or appeal by an unsuccessful Tenderer in accordance with the Act, the Procuring Entity may award the contract(s) to the successful Tenderer(s).
- 1.28.5 Until a formal contract is prepared and executed, the procuring entity shall provide written notification of contract award.

## **1.29. Signing of Agreement**

- 1.29.1 At the same time the Employer notifies the successful Tenderer that his Tender has been accepted, the Employer will send to the Tenderer the Form of Agreement provided in the Tender Document, incorporating all agreements between the parties.
- 1.29.2 Within 15 days of receipt of the Form of Agreement, the successful Tenderer shall sign the form and return it to the Employer.



### **1.30 Performance Security**

- 1.30.1 If required in the TDS, within 15 days of the signing of the contract, the successful Tenderer shall furnish to the Employer a performance security in the form of a Bank Guarantee or Performance Bond in the amount stated in the TDS.
  
- 1.30.2 The Bank Guarantee shall be in the Form provided herein and shall be issued by either a bank in the Virgin Islands or a foreign bank through a correspondent bank located in the Virgin Islands; or with the agreement of the Employer directly by a foreign bank acceptable to Employer. The Performance Bond by an insurance company, or surety acceptable to the Employer.

## 2. PROPOSAL AND EVALUATION

### 2.1 Submission Requirements

- 2.1.1 The tender must include responses to the questions and requests for information (RFI) detailed in Clause 4. The information provided will be used to evaluate the tender. All questions and RFI's should be fully answered or addressed, and specific details should be provided where requested. The completed tender questionnaire in conjunction with other requested information will provide the basis of tender analysis and award. On award of contract, the answers to these questions will form part of the contract and any changes must be agreed with the Employer.

### 2.2 Delivery

- 2.2.1 The following information concerning the delivery, or the services is intended to provide confidence in the Tenderer's organization, experience, and general ability to deliver the services required under this assignment:
- 2.2.2 Contact details of the Project Lead of the organization that will be involved with this tender.
- 2.2.3 Provide qualifications for the Project Lead that will be directly assigned to this project. Project Lead will be responsible for overseeing the entire work and should be suitably qualified in terms of academic qualifications and experience.
- 2.2.4 A list of company experience within the last ten (10) years that is relevant to the requirements of this assignment, including, but not limited to methodology, scale, and location. Specific experience undertaken to certain aspects of the work will be considered if complete similar experience is not identified.
- 2.2.5 A detailed work programme showing the order in which the various sections of work are to be executed, the rates of progress and the estimated periods of time for their execution and completion. A bar chart shall be submitted with these details.



### 2.3 Technical Proposal

- 2.3.1 Tenderers are required to provide in their technical proposal, the following minimum components:
- 2.3.2 Method statement of all works required to:
  - Consult with BVIAA’s air traffic services manager, operations managers, and engineering staff to assess the existing systems and minimize airport operation interruptions during installation.
  - Develop a detailed installation schedule, including work hours and BVIAA staff involvement.

### 2.4 Financial Proposal

- 2.4.1 The Tenderer shall submit with his tender a financial proposal that includes the proposed price for executing the services as well as financing options that are available to finance the project.
- 2.4.2 All prices included on the financial proposal shall be in United States dollars.
- 2.4.3 The tenderer is reminded that prices should include shipment and transportation costs as required.

### 2.5 Evaluation Criteria

- 2.5.1 The competitive bidding process, which the BVIAA’s Tender Committee supervises, will be utilized to ensure that the procurement process is transparent and that tenders are evaluated fairly to ascertain the lowest evaluated bid that is most technically and economically sound.
- 2.5.2 The Tenderers response to the Employer’s requirements will be evaluated under the following criteria with relative weights:

Table 2.1 Tender evaluation criteria and relative weights

Evaluation Criteria	Maximum Score (100 points)
<b>Qualifications</b> <ul style="list-style-type: none"> <li>• Identify a Construction Project Manager with academic qualifications and 5 to 10 years'</li> </ul>	25

<p>experience in commercial or institutional building construction. Provision of a clearly defined organisational chart outlining all roles and interactions (15-25 pts)</p> <ul style="list-style-type: none"> <li>• Identify a Construction Manager with 5 to 10 years' experience in commercial or institutional building construction but no academic qualifications. An organisational chart is provided, but roles are not clearly defined. (9 - 14 pts)</li> <li>• Identify a Construction Project Manager with less than 5 years' experience but no academic qualifications. Organisational chart is generic and not relevant (1 - 8 pts)</li> </ul>	
<p><b>Work Programme</b></p> <ul style="list-style-type: none"> <li>• Provide a work programme that pertains to this particular fire hall project that outlines with clarity all the tasks and summary stages of the project; demonstrates clearly how the project will be executed including site preparation, foundation works, building erection, MEP installations, and fit-out (9 - 15 pts)</li> <li>• Work programme is sufficient, but provides general summaries of tasks (5 - 8 pts)</li> <li>• Work programme is very limited and generic (1 - 4 pts)</li> </ul>	15
<p><b>Method Statement</b></p> <ul style="list-style-type: none"> <li>• Clearly demonstrates a full understanding of the processes and methods of how the fire hall will be constructed; identifies risks and mitigating measures, operational strategies for working in Anegada; defines clear strategies for undertaking all stages including foundation works, structural frame erection, MEP installations, and specialised fire hall requirements (25 - 35 pts)</li> <li>• Provides a substantially logical and relevant methodology covering all major elements, but does not clearly address potential issues and incorporate health and safety standards. Method statements are generally generic and do not incorporate the nuances of the fire hall project and work programme (16 - 24 pts)</li> <li>• Provides a methodology that covers some of the major elements, but is generally generic in nature and does not address the major components of the fire hall construction (10 - 15 pts)</li> </ul>	35



<ul style="list-style-type: none"> <li>Provides a methodology that is lacking in detail and generic (1 - 9 pts)</li> </ul>	
<p><b>Company Experience/Staff</b></p> <ul style="list-style-type: none"> <li>Completed at least 3 similar commercial/institutional building projects (fire stations, police stations, community centers, warehouses, or similar structures) within the last 10 years (17 - 25 pts)</li> <li>Completed at least 2 commercial or institutional building projects similar to certain aspects of this fire hall construction within the last 10 years (10 - 16 pts)</li> <li>Completed general commercial construction and building works within the last 10 years (1 - 9 pts)</li> </ul>	25

2.5.3 The Financial Score will be determined in the following manner:

2.5.4 The tender with the lowest evaluated Financial Proposal (that has achieved a minimum Technical Score of 70 points) will be awarded 100 points.

2.5.5 All other technically qualified proposals will be calculated as follows:

$$p = y (\mu/z)$$

where:

p = points for the financial proposal being evaluated

y = maximum number of points for the financial proposal

μ = price of the lowest priced proposal

z = price of the proposal being evaluated.

The Evaluated Score will be computed as,

$$0.7 \times (\text{Technical Score}) + 0.3 \times (\text{Financial Score})$$

The tender achieving the highest Evaluated Score will be selected as the preferred tenderer to engage in a contract to perform the Works.

## 2.6 Reporting System

2.6.1 The contractor will report directly to the Director of Airport Engineering and Maintenance, BVI Airports Authority or his/her designate.



- 2.6.2 English shall be the language used for all written and verbal communication related to this assignment (also referred to herein as services, works, or the Project).

## 2.7 Scheduling of Works

- 2.7.1 Completion Date: The Project is to be completed in accordance with the timelines as given in the tender and submitted by the Contractor in his Proposal and updated subsequent to the contract signing as agreed to by the Parties in writing.

## 2.8 Employer Inputs

- 2.8.1 The Employer agrees to provide the following information/access to the contractor:
- I. Access to the existing systems and relevant documents.
  - II. Counterpart staff to guide and monitor the project.
  - III. Assistance in structuring and hosting consultations.
  - IV. Financing for the project.

## 2.9 Variation and Change Management

- 2.9.1 It is possible that some aspects of the way the work is performed, or the nature of the service may vary during the course of the contract. Prior to any change being implemented, an impact assessment will be conducted by both parties to assess whether the change will impact on other aspects of the work. Changes will be negotiated and confirmed in writing by the Employer prior to implementation

## 2.10 Communication

- 2.10.1 Prior to the award of the contract, all communication with the **Employer** should be through the Tenders Secretary, BVI Airports Authority at the following contact details:

Tenders Secretary  
BVI Airports Authority  
Beef Island  
VG1110, British Virgin Islands  
Tel: (284) 394-8000  
Email: rfp@bviaa.com

- 2.10.2 After award of the contract, all communications with the **Employer** will generally be with the Director of Airport Engineering and Maintenance at the following contact details:

Director of Airport Engineering and Maintenance  
Terrance B. Lettsome International Airport  
British Virgin Islands Airports Authority  
Road Town, Tortola  
VG1110, British Virgin Islands  
Tel: (284) 342-7707  
Email: [ronnielettsome@bviala.com](mailto:ronnielettsome@bviala.com)

- 2.10.3 Regular contact with the Project Lead and the Director of Airport Engineering and Maintenance or designated officer by telephone or email is encouraged to address any issues that may arise.

## 2.11 Contractor's Roles and Responsibilities

- 2.11.1 The Contractor shall be responsible for executing the works as prescribed in the contract.
- 2.11.2 The Contractor shall be represented by a single-named Project Lead who will be responsible for liaising with the Director of Airport Engineering and Maintenance.
- 2.11.3 The Contractor shall be required to maintain correct versions of all documentation issued under this contract and to make his staff aware of any changes.

## 3. Payment, Rebates and Invoices

### 3.1 Introduction

- 3.1.1 This Section describes the basis on which the Employer will make payments to the Contractor and the Contractor will make payments or rebates to the Employer, after the contract is issued.

### **3.2 Payments for Contractor's Services**

- 3.2.1 Following acceptance of a deliverable and on receipt of a valid original invoice, the Employer will pay to the Contractor the Contract Price according to the agreed Priced Bill of Quantities.
- 3.2.2 Late delivery - In the event of late delivery beyond the agreed contract completion date, the Employer may apply damages at a rate of US\$500 for each day after the expiration of the agreed completion date.
- 3.2.3 Other charges - In the event that the Contractor is required to use other reasonable and unforeseeable services in order to complete the contract, the charges will be agreed upon by both Contractor and Employer; provided that the Contractor shall not perform these additional services without the prior written consent of the Employer.

### **3.3 Submission of Invoices for Additional Services**

- 3.3.1 Correct invoices for additional services supplied by the Contractor will be submitted to the Employer monthly in arrears for such services having been performed.

### **3.4 Submission of Invoices**

- 3.4.1 Correct invoices corresponding to each completed service should be addressed to:

Director of Airport Engineering and Maintenance  
Terrance B. Lettsome International Airport  
British Virgin Islands Airports Authority  
Road Town, Tortola  
VG1110, British Virgin Islands

Tel: (284) 342-7707

### **3.5 Netting**

- 3.5.1 All Contractor invoices will be submitted net of charges invoiced by the Employer. In the event that any work is rejected by the Employer or its Agent for reasons of poor quality, the Employer



at its sole discretion will deduct all expenses associated with re-testing from any amounts to be paid to the contractor

### **3.6 Payment Process**

- 3.6.1 The Employer will pay against original invoices (fax or other copies are not acceptable) once the Director of Airport Engineering and Maintenance or his designate has verified that the work meets the required quality standards.



## 4. TENDER DATA SHEET (TDS)

ITT 1.1	The Employer is: <b>British Virgin Islands Airports Authority.</b>
ITT 1.2	<i>Not applicable</i>
ITT 1.3	The date and time for pre-tender meeting <b>Friday, June 12, 2026 at 10:00 A.M. local time.</b>
ITT 1.4	<p>The address is:</p> <p>Terrance B. Lettsome International Airport Beef Island British Virgin Islands</p> <p>Email: rfp@bviaa.com Telephone: (284)394-8000</p> <p>The time for receiving clarification of tender documents is no later than <b>14 days before the deadline for submission of tenders.</b></p>
ITT 1.5	The language of the tender is English <u>only</u> . Another language is <u>not</u> permitted.
ITT 1.6	The time for requests for modification of tender documents is no later than <b>14 days before the deadline for submission of tenders.</b>
ITT 1.7	The Tender Validity Period shall be 120 days.
ITT 1.8	A Tender Security is <u>not required</u> .
ITT 1.9	Variant or alternative solutions are <u>not permitted</u> .
ITT 1.10	The date and time for submission of tenders are <b>no later than <u>Tuesday, June 30, 2026 at 12:00 noon local time.</u></b>
ITT 1.11	The date and time for opening of tenders are <b><u>Tuesday, June 30, 2026 at 2:00 pm local time.</u></b>
ITT 1.12	A performance security of 10% of the Contract Price is required.



## 5. FORM OF TENDER

To: Chairman  
Procurement Committee  
BVI Airports Authority  
Beef Island  
British Virgin Islands

### TENDER

Tender for the construction of a Fire Hall - Auguste George International Airport.

Dear Chairman:

1. We have examined and taken into account the documents provided in this Invitation to Tender, including its attachments, drawings and specifications, General Conditions of Contract, particular Conditions of Contract, clarifications to the documents, and addenda pursuant to this invitation.

We offer to execute and complete the works and remedy any defects therein in conformity with this Tender inclusive of all the above listed documents for the sum of (US\$) (sum in words and figures)

---

payable by the British Virgin Islands Airports Authority.

2. We agree that the proper law of the Contract shall be the Laws of the Virgin Islands.
3. We agree that these tender documents and the terms and conditions of contract shall comprise the sole binding documentation applicable to this tender or to the contract.
4. We agree that all information supplied by the Employer to the Tenderer will be treated in confidence and not disclosed to third parties except insofar as this is necessary to obtain sureties or quotations for the purpose of submitting the tender. All information supplied by the Tenderer to the Employer will similarly be treated in confidence, except that references may be sought from banks, existing or past clients, or other referees submitted by the Tenderer.
5. We have provided with our tender the priced Bills of Quantities, which were used for calculating the Tender Sum. These Bills shall form part of our Tender and we



agree that in the event of a contract being awarded the rates in the said Bills shall be used for the measurement and valuation of any alteration in, addition to or omission from the Works as described in the Specification and/or Drawings.

We accept full responsibility for the accuracy of all prices provided in this tender and agree that these prices include full provision for any increases in the costs for whatsoever reason over the period of time from submission of tender to completion of the project and settlement of the final account.

- 6. We accept that any and all omissions or errors in pricing are our responsibility and agree that should any errors in arithmetic be discovered in the Bills of Quantities submitted by us during consideration of this offer, these errors will be corrected by giving us an opportunity of either confirming our offer or amending it to correct such errors.
- 7. We have included in our tender for taxes, fees and all charges applicable to materials, appliances, labor and all things subject to and upon which taxes or other charges may be levied (where required by the draft contract form included in the tender documents), and have made allowance for currency exchange rates.
- 8. If this tender is accepted and subject to and in accordance with paragraphs 2, 3, 4, 5, 6, and 7 above and the terms and conditions contained or referred to in the documents listed in paragraph 1, we undertake to commence the works as soon as is reasonably practicable after the commencement date and complete the works within a period of \_\_\_\_\_ months, from commencement on site.
- 9. We further agree that acceptance of this tender by the BVI Airports Authority does not constitute an offer, an invitation to offer, nor a legally binding contract agreement between the BVI Airports Authority, myself, my company, or any other entity associated with this tender submission.

Signed .....

Name in

Block Capitals.....

In the capacity of .....

Duly authorized to sign tenders for and on behalf of

Name .....

Address .....

.....

Telephone No .....



AUGUSTE GEORGE INTERNATIONAL AIRPORT FIRE HALL.

Email Address: .....

Date .....



## 6. CERTIFICATE OF VISIT TO SITE

1. This is to certify that I, \_\_\_\_\_ (Name of Tenderer or his Representative) of the Company

\_\_\_\_\_

visited the Site on \_\_\_\_\_2026 in connection with the tender for:

Tender for the construction of a Fire Hall - Auguste George International Airport.

2. Having previously studied the Tender Documents, I have carefully examined the Site.

3. I have made myself familiar with all the local conditions influencing the works and the cost thereof.

4. I further certify that I understand fully the works to be done as specified and to be executed under the Contract.

5. Signature of Tenderer or his Representative:

Date: \_\_\_\_\_

Signature: \_\_\_\_\_

Name: \_\_\_\_\_

Position: \_\_\_\_\_



## 7. STATEMENT OF EXPERIENCE ON SIMILAR PROJECTS

Provide an account of past projects demonstrating experience in the works required under this tender.

Item No.	Client Name, Address, Representative and Phone No.	Description of Works	Location	Value (US\$)	Start/End dates	Notable Successes



## 8. CURRENT CONTRACT COMMITMENTS/ WORK IN PROGRESS

Please note that the below form “Current Contract Commitments/Works in Progress must be completed and returned with your bid package. This form must be fully completed for any private or government contract. If tenderer do not have any contract, it must be stated on the form. The form must not be returned incomplete.

Tenderers and each partner to a JVCA should provide information on their current commitments on all contracts that have been awarded, or for which a letter of intent or acceptance has been received, or for contracts approaching completion, but for which an unqualified, full completion certificate has yet to be issued.

Name of contract	Employer contact information (address, telephone, email)	Value of current outstanding work (US\$)	Estimated start date	Estimated completion date



9. **FORM OF AGREEMENT**

THE BVI AIRPORTS AUTHORITY LIMITED

AND

[ ]

---

**AGREEMENT**

(for the construction of the a Fire Hall at the Auguste  
George International Airport)

---





Contents

1	Definitions and interpretation .....	36
2	Commencement and duration of Project.....	41
3	Provision of Equipment and Services.....	41
4	Outside interests, conflicts and protection of Authority's business interests .....	42
5	Contract Price and payment .....	43
6	Expenses .....	44
7	Tax liability, national health insurance and social security contributions .....	44
8	No employment or benefits.....	44
9	Liability, indemnity and insurance.....	45
10	Confidential Information .....	45
11	Risk and title to the Equipment .....	46
12	Intellectual property .....	46
13	Data protection and monitoring .....	47
14	Anti-bribery and corruption .....	48
15	Obligations of the Authority .....	48
16	Public statements and announcements.....	48
17	Breach, suspension and termination.....	48
18	Obligations on termination.....	50
19	Restrictions on assignment/sub-contracting.....	51
20	Notices.....	51
21	Entire agreement.....	51
22	Further assurance .....	51
23	Variation .....	51
24	Set off.....	51
25	No partnership or agency .....	52
26	Remedies and waiver .....	52
27	Equitable relief .....	52
28	Severability.....	52
29	Counterparts.....	52
30	Legal expenses.....	52
31	Resolution of disputes .....	52
32	Governing law .....	53
	The Schedule.....	54

## PARTIES

- (1) THE BVI AIRPORTS AUTHORITY LIMITED, a company incorporated under the laws of the Virgin Islands with BC number 1000199 whose registered office is at Craigmuir Chambers, Road Town, Tortola VG1110, British Virgin Islands and having a place of business at the Terrance B Lettsome International Airport, Administration Centre, Beef Island VG1120, British Virgin Islands (the **Authority**); and
- (2) [ ] (the **Contractor**).

## BACKGROUND

- A The Authority is the manager and operator of the Terrance B Lettsome International Airport (the **Airport**) which is the main airport serving the British Virgin Islands.
- B The Airport issued a request for proposal dated [ ] for the construction of a fire hall at the Auguste George International Airport, and the Contractor is the successful tenderer.
- C The Authority wishes to engage the Contractor as an independent contractor to provide the Services to the Authority on the terms and conditions of this Agreement, and the Contractor is an independent contractor willing to provide the Services to the Authority on the terms and conditions of this Agreement.

## THE PARTIES AGREE:

### 1 Definitions and interpretation

- 1.1 In this Agreement, unless the context requires otherwise, the following words and phrases have the meanings set opposite them:

**Agreement** this Agreement including the schedule;

**Airport** is as defined in Recital A;

**Board** the board of directors from time to time of the Authority or any committee of the Board duly appointed with oversight of the Project on behalf of the Board;

**Bribery Laws** all applicable BVI legislation, statutory instruments, regulations, codes and sanctions relating to anti-bribery and anti-corruption including the Contractor General, Act, 2021, the Integrity in Public Life Act, 2021, the Public Procurement Act, 2021, the Public

Procurement Regulations, 2022 and the Criminal Code;

***British Virgin Islands***

the British Overseas Territory of the Virgin Islands known legally as the ***Virgin Islands***, commonly as the ***BVI*** and also as the Virgin Islands (UK);

***Business Day***

a day on which banks are open for general business in the Virgin Islands but shall not include any day which is:

- (a) a Saturday or Sunday;
- (b) a recognised public holiday in the Virgin Islands;
- (c) the Friday immediately preceding the first Monday in August in any year;
- (d) 24 December;
- (e) 31 December; and
- (f) any day on which Government offices are closed upon the recommendation of the Department of Disaster Management in the Virgin Islands; and
- (g) any day on which Government offices are closed upon the declaration of a State of Emergency by His Excellency, the Governor;

***Commencement Date***

[        ];

***Confidential Information***

all information or data of a confidential or proprietary nature (in whatever form that may take including written form, electronically stored information, drawings, specifications, code, samples, prototypes) disclosed to or received by the Contractor (whether in writing, orally or by any other means) or to which the Contractor has access and whether or not labelled or designated as confidential and includes:

- (a) information relating to the products, services, business, proposed business, finances, transactions, workforce and affairs of the Authority and/or Government for the time being confidential to the Authority **and/or Government**;
- (b) Intellectual Property Rights of the Authority and/or Government;
- (c) trade secrets (including price and cost information, discount structures, sales statistics, business plans and programs, business opportunities, expansion plans, marketing

surveys, research and development projects, formulae, inventions, designs, discoveries, know-how, methods, processes, techniques, other technical data, operating procedures, policies and practices relating to the business of the Authority and/or Government and which are for the time being confidential to the Authority and/or Government;

- (d) information relating to the business, finances, dealings, transactions and affairs of any client, customer or supplier of the Authority and/or Government;
- (e) information in respect of which the Authority and/or Government is bound by an obligation of confidentiality to a third party; and
- (f) any other information which is designated as confidential by the Authority and/or Government or which because of its character or the circumstances or manner of its disclosure is evidently confidential;

***Contractor's Personnel***

the Contractor's partners, directors, officers, employees and representatives designated and appointed by the Contractor to provide the Services to the Authority under this Agreement;

***Contract Price***

[     ];

***Force Majeure Event***

an event which is beyond the reasonable control of a party, is not foreseeable, is unavoidable, and makes a party's performance of its obligations hereunder impossible or so impractical as reasonably to be considered impossible under the circumstances, and subject to those requirements, includes, but is not limited to, any act of God, hurricane or other windstorm, flood, drought, earthquake or other natural disaster, fire, act of the Government, other public bodies or the state, war, civil commotion, insurrection, embargo, prevention from or hindrance in obtaining any raw materials, energy or other supplies, labour disputes and industrial action of whatever nature and any other reason beyond the control of either party provided however that *Force Majeure Event* shall not include insufficiency of funds or failure to make any payment required by the terms of this Agreement;

<b>Equipment</b>	Metal building structure currently stored onsite, including all structural components, associated fasteners and fixtures as procured by the BVIAA;
<b>Government</b>	the Government of the British Virgin Islands;
<b>Governor</b>	the person appointed pursuant to section 35(1) of the Virgin Islands Constitution Order 2007 to hold the office and act in the capacity of Governor of the Territory of the Virgin Islands from time to time;
<b>Insurance Policies</b>	general liability insurance with minimum limits in the aggregate of US\$1,000,000.
<b>Intellectual Property Rights</b>	<p>this refers to any and all copyright, rights in inventions, patents, know-how, trade secrets, trademarks and trade names, service marks, design rights, rights in get-up, database rights and rights in data, the right to sue for passing off, utility models, domain names and, in each case:</p> <ul style="list-style-type: none"> <li>(a) whether registered or not;</li> <li>(b) including any applications to protect or register such rights;</li> <li>(c) including all renewals and extensions of such rights or applications;</li> <li>(d) whether vested, contingent or future; and</li> <li>(e) wherever existing;</li> </ul>
<b>Managing Director</b>	the person acting in and or holding the position of Managing Director of the Authority as appointed by the Board from time to time;
<b>Personal Data</b>	<p>any information relating to a living individual who can be identified, directly or indirectly, in particular by reference to:</p> <ul style="list-style-type: none"> <li>(a) an identifier such as a name, an identification number, location data or an online identifier, or</li> <li>(b) one or more factors specific to the physical, physiological, genetic, mental, economic, cultural or social identity of the individual;</li> </ul>
<b>Project</b>	The construction of a Fire Hall at the Auguste George International Airport is the subject of this Agreement;
<b>Project Delivery Timeline</b>	the projected timeline for production of the deliverables and for delivery or completion of the Project;

<i>Projects Director</i>	the person employed in that capacity from time to time by the Authority;
<i>Proposal</i>	the Contractor's proposal issued on [ ] in response to the RFP;
<i>RFP</i>	is as defined in Recital B;
<i>Scope of Services</i>	the services set out and defined in Part A of the schedule to this Agreement;
<i>Services</i>	installation of the Equipment and providing training to the Authority's staff in respect of the operation and maintenance of the Equipment , in accordance with the Scope of Services;
<i>Term</i>	[ ]
<i>Termination Date</i>	the date of termination of this Agreement for whatever reason;
<i>Work</i>	without limitation any and all works of authorship, products, materials, discoveries, inventions, research, processes, systems, programs (including software programs and source code), formulae, component lists, operating and training manuals, databases, instructions, manuals, brochures, catalogues, process descriptions, know-how, data, diagrams, charts, results, reports, information, methodologies, ideas, concepts, designs, documents, models, prototypes, sketches, drawings, plans, photographs, specifications and studies created or developed by the Contractor in providing the Services either alone or jointly with others.

1.2 In this Agreement:

- 1.2.1 the schedule is incorporated into and forms part of this Agreement.
- 1.2.2 any reference to this Agreement or to any other document will include its Schedules, appendices and annexes (if any) and any permitted variation or amendment to this Agreement or such other document;
- 1.2.3 any reference to a Clause or Schedule is, except where expressly stated to the contrary, reference to the relevant Clause of or Schedule to this Agreement;
- 1.2.4 the table of contents, background section and any Clause, Schedule or other headings and the use of bold type in this Agreement are included for convenience only and shall have no effect on the interpretation of this Agreement;
- 1.2.5 a reference to any statute, statutory instrument, order, regulation or other similar instrument will be construed as including references to any statutory

modification, consideration or re-enactment of that provision (whether before, on or after the date of this Agreement) for the time being in force, including all instruments, orders or regulations then in force and made under or deriving validity from that legislation;

- 1.2.6 the words 'include', 'including', 'in particular' or any similar words and expressions will be construed as illustrative only and will not limit the sense of any word, phrase, term, definition or description preceding those words;
- 1.2.7 the use of the singular includes the plural and vice versa and a reference to one gender includes a reference to the other gender;
- 1.2.8 a reference to 'writing' or 'written' includes any method of reproducing words in a legible and non-transitory form (excluding email);
- 1.2.9 a reference to a 'party' includes that party's personal representatives, successors and permitted assigns;
- 1.2.10 a reference to a 'person' includes a natural person, corporate or unincorporated body (in each case whether or not having separate legal personality) and that person's personal representatives, successors and permitted assigns;
- 1.2.11 a reference to a 'company' includes any company, corporation or other body corporate, wherever and however incorporated or established;
- 1.2.12 a reference to the Contractor's Personnel shall, where the context admits, be a reference to the Contractor; and
- 1.2.13 a reference to timely for the purposes of this Agreement means as soon as reasonably practicable after receipt of a request.

## **2 Commencement and duration of Project**

Subject to the terms of this Agreement, the Contractor's engagement will commence on the Commencement Date and will continue up to completion of the Contractor's performance and delivery of the Equipment and Services or the Termination Date, whichever is earlier.

## **3 Provision of Equipment and Services**

### **3.1 The Contractor has agreed to provide:**

3.1.1. the Services; and

3.1.2. the Equipment,

to the Authority subject to the provisions of this Agreement.

### **3.2 During the Project, the Contractor shall:**

3.2.1 provide and complete the delivery of the Equipment and Services to the Authority on such days and at such times and in such places as may be required by the Authority from time to time and as necessary in the estimation of the Authority for the proper provision of the Services and in accordance with the Project Delivery Timeline;

3.2.2 provide the Services to the Authority with all due care, skill and diligence and use its best endeavours to protect the interests of the Authority **and the Government in connection with the Project**; and

3.2.3 work efficiently in the delivery of the Services to keep expenses to a minimum and in a manner consistent with sound professional practice and in keeping with the Project Delivery Timeline.

### **3.3 The Contractor acknowledges that the Authority and the Government will be relying upon its skill, expertise and experience in connection with the Services it agrees by virtue of this Agreement it will perform and undertakes to the Authority that:**

- 3.3.1 it will provide the Services in the manner and to the standard specified by the Authority and in keeping with the level of skill and care expected of professionals in the field of endeavour engaged in by the Contractor, applying sound and acceptable professional practice;
- 3.3.2 all advice and information given, all representations and statements made, all documents and devices provided by the Contractor will be sound and appropriate for their purpose; and
- 3.3.3 all intellectual property and information provided by the Contractor will be materially accurate and appropriate for its purpose.
- 3.4 The Contractor shall not be relieved from the obligation to provide the Equipment and perform the Services in full by virtue of expiration of the Term.
- 3.5 While the Contractor's method of work is its own, the Contractor will comply with the reasonable requests of the **Authority** and will work and co-operate with any servant or agent or other contractor of the Authority as may be necessary for the provision of the Equipment and performance of the Services, provided such requests are within the scope of work of this Agreement.
- 3.6 The Contractor:
  - 3.6.1 will not hold itself out as having authority to bind the Authority; nor
  - 3.6.2 does not have any authority to incur any expenditure in the name of or on behalf of, or otherwise bind, the Authority.
- 3.7 The Contractor will ensure that while at the Airport engaged in performance of the Services, Contractor's Personnel will, at all times:
  - 3.7.1 comply with all reasonable standards of safety;
  - 3.7.2 comply with the Authority's health and safety policies and procedures as are notified to the Contractor from time to time; and
  - 3.7.3 immediately report to the **Managing Director** any unsafe working conditions or practices.
- 3.8 The Contractor will, at its own cost, keep any instruments, equipment, and/or computer equipment and electronic devices it provides in relation to the provision of the Services in a safe and proper operating condition.
- 3.9 Where the Contractor is obliged to integrate the Equipment or any other computer equipment into the Authority's existing systems in relation to the provision of the Services, it is a condition of this Agreement that:
  - 3.9.1 such Equipment or computer equipment, including any storage devices and storage media used with it, are free of any virus or malware;
  - 3.9.2 the Contractor will on the Commencement Date and from time to time as required by the Authority, make such computer equipment available for audit by the Authority's information technology team, for verification of Clause 3.9.1 requirements; and
  - 3.9.3 the Contractor will procure that Contractor's Personnel will not connect the Equipment or computer equipment to the Authority's computer network without the Authority's prior written permission.
- 4 Outside interests, conflicts and protection of Authority's business interests**
- 4.1 The Contractor warrants that:
  - 4.1.1 the Contractor will not as a consequence of entering into and performing this Agreement, be in breach of any express or implied terms of any contract, agreement or other arrangement with, or any obligation to, any third-party binding upon the Contractor; and

- 4.1.2 there is no contract, obligation, or other arrangement or interest that will or may give rise to any conflict of interest between the Contractor and the Authority in relation to the provision of the Services.
- 4.2 The Contractor will use all reasonable endeavours to avoid a conflict of interest arising between the Contractor and the Authority, and the Contractor undertakes to notify and disclose the same in full to the Authority as soon as reasonably practicable should any actual or potential conflict of interest arise.
- 4.3 The Contractor will not use or otherwise turn to its advantage, its knowledge of or any connection with any of the customers of or suppliers to the Authority and/or the Government which it acquired during the provision of the Services or otherwise on account its participation in the Project so as to take any direct or indirect advantage of the business and other connections of the Authority except:
- 4.3.1 for the Authority's advantage and/or the advantage of the Government; and/or
- 4.3.2 where the Contractor (or any of its directors) has a pre-existing relationship with such customers or suppliers as at the Commencement Date.
- 4.4 The Contractor will not receive or obtain directly or indirectly any discount, rebate, commission or other benefit in respect of any goods or services supplied to or acquired by the Authority or any other business transacted by it and if it does receive any such discount, rebate, commission or other benefit the Contractor will account to the Authority for it immediately.
- 4.5 The Contractor acknowledges and agrees that it will be obliged to draw the provisions of this Clause 4 to the attention of any third party who may at any time before or (where the restrictions apply after the Termination Date) after the Termination Date, offer to engage or go into business with the Contractor in any capacity and for whom or with whom the Contractor intends to work or go into business at any time within the period of 12 months following the Termination Date.
- 5 Contract Price and payment**
- 5.1 Subject to the terms of this Agreement, the Authority will pay to the Contractor, in consideration of the provision of the Equipment and Services, a Contractor's fee in the amount of the Contract Price, less deductions required by law, if any as follows [ ].
- 5.2 Notwithstanding any other provision of this Agreement appearing to be contrary to the terms of this Clause 5.2, the Authority shall be entitled to retain [ ]% of the Contract Price pending completion of delivery the Services by the Contractor to the reasonable satisfaction of the Authority.
- 5.3 [The Contractor will and will procure that the Contractor's Personnel will record accurately the time spent in respect of the provision of the Services and shall keep accurate time sheets showing the hours worked and if so requested, produce them to the Authority for accounting purposes.]
- 5.4 Where the Authority disputes in good faith and on reasonable grounds any sum invoiced by the Contractor, the Authority may, without penalty, withhold payment in respect of the amount under dispute, pending resolution of the dispute.
- 5.5 Payment by the Authority of any invoice will be without prejudice to any claims or rights which the Authority may have against the Contractor and will not constitute any admission by the Authority as to the provision of the Services by the Contractor under this Agreement.
- 5.6 The Authority will be entitled to deduct from the Contract Price (and any other sums) due to the Contractor any sums that the Contractor may owe to the Authority at any time, including any sum under dispute in accordance with Clause 5.4.

5.7 For the avoidance of doubt, the parties acknowledge that if the Contractor fails or is unable, through no fault of the Authority or the Government, to provide the Services (whether by reason of illness, accident or other incapacity of the Contractor's Personnel, or for any other reason), no Contract Price will be payable.

## **6 Expenses**

The Contractor will be responsible for all out-of-pocket expenses and normal overhead expenditure incurred by it in the performance of its duties under this Agreement except that the Contractor will be entitled to be reimbursed including such expenses as are reasonably incurred by the Contractor in the proper provision of the Equipment and Services, subject to prior agreement in writing by the Authority and to the production of such receipts or other evidence as the Authority may reasonably require.

## **7 Tax liability, national health insurance and social security contributions**

7.1 The Contractor will, as far as is required by law, be responsible for and will account and pay to the appropriate authorities for all tax liabilities (including payroll tax, national health insurance and social security contributions, and income tax, as applicable, or their jurisdictional equivalents) whether arising in the Virgin Islands or in any other jurisdiction and any other liability, deduction, contribution, assessment or claim arising from or made in connection with fees paid and/or benefits provided as a result of the performance of the Services.

7.2 The Contractor shall, as a condition precedent to this Agreement, have provided evidence of good standing status with the Social Security Board, National Health Insurance Scheme and the Inland Revenue Department in the Virgin Islands, to the extent applicable.

7.3 If any claim, assessment or demand is made against the Authority **in the Virgin Islands** for payment of any tax liability arising from or due in connection with either the performance of the Services or any payment or benefit received by the Contractor in respect of the performance of the Services, the Contractor will, where such recovery is not prohibited by law, indemnify the Authority against any liability, claim, assessment or demand. The Contractor will further indemnify the Authority against all costs and expenses and any penalty, fine or interest incurred or payable or paid by the Authority in connection with or in consequence of any such liability, assessment or claim other than where such costs, expenses or any penalty, fine or interest arise out of the Authority's negligence or wilful default.

## **8 No employment or benefits**

8.1 While acting as a Contractor for the Authority, the status of the Contractor will be that of an independent contractor and as such:

8.1.1 the Contractor and/or Contractor's Personnel will not be entitled to any pension, bonus, holiday, sickness or other fringe benefits from the Authority;

8.1.2 nothing in the terms of this Agreement will render the Contractor or the Contractor's Personnel an agent, officer, employee, worker or partner of the Authority; and

8.1.3 the Contractor will not hold itself out as an agent, officer, employee, worker or partner of the Authority, and will procure that the Contractor's Personnel will not hold themselves out as such.

8.2 The Contractor will be fully responsible for, and will indemnify the Authority for and in respect of any liability for any employment-related claim or any claim based on worker status (including reasonable costs and expenses) brought by the Contractor's Personnel against the Authority arising out of or in connection with the provision of the Services.

## **9 Liability, indemnity and insurance**

- 9.1 The Authority shall bear no responsibility in respect of any life, health, accident, travel or other insurance, which may be necessary or desirable for the Contractor or the Contractor's Personnel, to facilitate the delivery of the Services to the Authority, nor for any dependent of any such person in any circumstance whatsoever.
- 9.2 The Contractor will be liable for any loss, liability, costs (including reasonable legal costs), damages or expenses incurred by the Authority in connection with the provision of the Equipment and Services by the Contractor and will accordingly maintain in force at all times during the subsistence of this Agreement at its own cost, full and comprehensive Insurance Policies.
- 9.3 The Contractor confirms that it holds Insurance Policies with reputable insurers.
- 9.4 At the request by the Authority, the Contractor will produce a letter from the Contractor's insurers confirming the Insurance Policies.
- 9.5 The Contractor will comply, and will procure that the Contractor's Personnel will comply, with all terms and conditions of the Insurance Policies at all times. The Contractor will immediately notify the Authority if cover under the Insurance Policies is not renewed, or lapses, or is cancelled or otherwise subject to material change, and/ or if the Contractor becomes aware of any circumstances which may cause cover under the Insurance Policies not to be renewed, or to lapse, or to be cancelled or otherwise subject to material change.
- 9.6 The Contractor agrees to indemnify the Authority against any loss or costs (including reasonable legal costs), charges and other expenses of any nature whatsoever incurred or suffered by the Authority whether direct or consequential including such arising in consequence of a claim brought against the Authority in consequence of any breach of any of the terms of this Agreement and/or any gross negligence on the part of the Contractor in connection with the provision of the Equipment and Services.

## **10 Confidential Information**

- 10.1 Except in the proper performance of its obligations under this Agreement, the Contractor will not during the period of this Agreement or at any time after the Termination Date, without the prior written approval of the Authority, use for its benefit or for the benefit of any other person, firm, company or organisation or directly or indirectly divulge or disclose to any person (and must use best endeavours to prevent publication or disclosure of) any Confidential Information which has come, or may come, to the Contractor's knowledge during or in connection with the Services.
- 10.2 The Contractor will not during the period of this Agreement make (otherwise than for the benefit of the Authority including in connection with the performance of the Services) any notes, memoranda, records, tape recordings, computer programs or any other form of record relating to any matter within the scope of the business of the Authority or concerning any of the dealings or affairs of the Authority.
- 10.3 The restrictions contained in this Clause 10 will not apply to:
- 10.3.1 any Confidential Information which is already in or (otherwise than through the Contractor's unauthorised disclosure) becomes available to, or within the knowledge of, the public generally;
- 10.3.2 the Contractor's disclosure of Confidential Information where it wishes to disclose it to its insurers or advisers, in which event it may do so in confidence only; and
- 10.3.3 any use or disclosure required by law, and if not prohibited under the law based on the circumstances, the Contractor shall advise the Authority in advance.

10.4 The Contractor warrants to the Authority that its representatives and employees working on the Project have given or will give written undertakings, in the same terms as those contained in this Clause 10, to the Contractor and agrees to provide copies of such undertakings to the Authority on or before the Commencement Date or, if later, when such individual commences work on the Project or such later date agreed in writing with the Authority.

## 11 Risk and title to the Equipment

11.1 The Contractor warrants that:

11.1.1. it has full clear and unencumbered title to all the Equipment;

11.1.2. at the date of delivery of the Equipment, or any of them, it shall hold such title in the Equipment; and

11.1.3. at the date of delivery of the Equipment, or any of them, it will have full and unrestricted right, power and authority to sell, transfer and deliver all of the Equipment to the Authority and from that date the Authority shall acquire a valid and unencumbered title to the Equipment .

11.2 The Equipment will be at the Contractor's risk until:

11.2.1 the Equipment are delivered to the Authority; and

11.2.2 the Equipment are found by the Authority to be in accordance with the provisions of this Agreement.

## 12 Intellectual property

12.1 The Consultant warrants to the Authority that it:

12.1.1 holds with full title guarantee of all the Intellectual Property Rights in the Work:

(a) existing anywhere in the world;

(b) relating to their use in any sector and for any purpose;

(c) for the full term of such rights and any renewals;

(d) including (with effect from their creation) all Intellectual Property Rights created or developed in future by the Consultant's Personnel in respect of the Services.

12.2 In consideration of the Authority paying the Contract Price to the Consultant, the Consultant hereby transfers to the Authority by way of present and future assignment with full title guarantee all the Intellectual Property Rights:

12.2.1 anywhere in the world;

12.2.2 in any sector and for any purpose;

12.2.3 for the full term of such rights and any renewals;

12.2.4 including (with effect from their creation) all Intellectual Property Rights created or developed in future by the Consultant and the Consultant's Personnel in respect of the Services.

12.3 For Work in respect of which Intellectual Property Rights are assigned to the Authority pursuant to Clause 12.2, the Consultant will waive its, and will procure the waiver by all third parties of their moral rights in such Work under the applicable intellectual property laws in the Virgin Islands (and all analogous worldwide) to the extent permitted by law.

12.4 The Consultant will, at the expense of the Authority, at any time either during or after the Project give assistance and do all acts and things as may be in the opinion of the Authority necessary or desirable to give the full benefit of this Agreement to the Authority including registration of the Authority as applicant or (as applicable) proprietor of the Intellectual Property Rights; and assisting the Authority in obtaining, defending

and enforcing the Intellectual Property Rights, and assisting with any other proceedings which may be brought by or against the Authority against or by any third party relating to the Intellectual Property Rights.

- 12.5 The Consultant hereby irrevocably and by way of security appoints the Managing Director and the Authority's Director of Airport Engineering and Maintenance for the time being and in that capacity to be its attorneys for with authority to do all such things and to execute all such documents in its name and on its behalf, as may be necessary to secure that the full benefit and advantage of Clauses 12.2, 12.3 and 12.4 of this Agreement and a letter signed by any director or officer of the Authority certifying that anything or any document has been done or executed within the authority conferred by this clause will be conclusive evidence of it.
- 12.6 The Contractor warrants that it will not in the course of providing the Services infringe the Intellectual Property Rights of any other person.
- 12.7 The Contractor will indemnify and keep indemnified and hold harmless the Authority from and against any losses, damages, liability, costs (including legal fees) and expenses incurred by the Authority as a result of or in connection with any action, demand or claim that any of the Intellectual Property Rights or Work generated under this Agreement infringe the Intellectual Property Rights of any third party.

### **13 Data protection and monitoring**

- 13.1 To the extent that the Contractor shall be required to process Personal Data on behalf of the Authority to meet its obligations under this Agreement, it shall obtain the Authority's prior written consent.
- 13.2 The Contractor will, in relation to any Personal Data processed in connection with the Project:
- 13.2.1 co-operate fully with the Authority in order to enable the Authority to comply with its obligations under applicable data protection laws;
  - 13.2.2 keep the Personal Data confidential;
  - 13.2.3 implement and maintain appropriate technical and organisational measures, reviewed and approved by the Authority if it so requires, to protect against unauthorised and unlawful processing of Personal Data and against accidental loss and destruction of, or damage to, Personal Data;
  - 13.2.4 process any Personal Data disclosed to the Contractor by or on behalf of the Authority only:
    - (a) on the written instructions of the Authority;
    - (b) for the purposes of providing the Services; and
    - (c) for the purposes for which that Personal Data was obtained and is processed by the Authority;
  - 13.2.5 maintain complete and accurate records and information to demonstrate compliance with applicable data protection legislation and immediately provide such evidence of compliance by the Contractor with the obligations under this Clause 13.2 as the Authority may from time to time reasonably request;
  - 13.2.6 immediately upon notification by the Authority, take all appropriate action to enable the Authority to properly comply with any request from a data subject in relation to access to and/or rectification or erasure of Personal Data;
  - 13.2.7 immediately notify the Authority of any data breach relating to Personal Data or any communication which relates to the Authority's or the Contractor's compliance with applicable data protection legislation about which the Contractor becomes aware; and

13.2.8 at the Authority's written request, delete or return all Personal Data and any copies on termination of the Agreement, unless required to store the Personal Data under applicable data protection laws.

13.3 The Authority may monitor the activities of Contractor's Personnel in accordance with its policies relating to *email, internet and communications systems and monitoring at work*.

#### **14 Anti-bribery and corruption**

14.1 The Contractor will:

14.1.1 comply with the Bribery Laws;

14.1.2 not engage in any activity, conduct or practice which would constitute an offence under the Bribery Laws;

14.1.3 ensure that it has in place adequate procedures to prevent bribery and use all reasonable endeavours to ensure that it complies with any Authority policies relating to prevention of bribery and corruption (as updated from time to time).

14.2 Without limitation to the above sub-clause, neither party will make or receive any bribe (as defined in the Bribery Laws) or other improper payment, or allow any such bribe or other improper payment to be made or received on its behalf, either in the Virgin Islands or elsewhere, and each party will implement and maintain adequate procedures to ensure that such bribes or payments are not made or received directly or indirectly on its behalf.

14.3 Each party will use all reasonable endeavours to ensure that:

14.3.1 all of that party's personnel;

14.3.2 all others associated with that party; and

14.3.3 all of that party's subcontractors,

involved in performing the Services or with this Agreement comply with the obligations set out in Clauses 14.1 and 14.2.

#### **15 Obligations of the Authority**

15.1 For the duration of the Agreement, the Authority will afford the Contractor such access to the Airport including, to information, records and other materials of the Authority as may be necessary to enable the Contractor to provide the Services.

15.2 The Authority will:

15.2.1 advise the Contractor of the rules and regulations from time to time in force for the conduct of personnel at its premises and the Contractor will ensure that Contractor's Personnel comply with any such rules and regulations;

15.2.2 make available such working space and facilities at its premises as the Authority deems necessary for the Contractor and the Contractor's Personnel to provide the Services; and

15.2.3 confer with the Contractor to schedule work to the best convenience of both parties.

#### **16 Public statements and announcements**

The Contractor will not without the prior written consent of the Authority, at any time whether during the Agreement or at any time after it ends make any public statement or announcement in relation to the Project, the Authority **or the Government** or their business, affairs, customers or clients or officers and employees and will not after the Termination Date represent itself as continuing to be engaged by or connected with the Authority or the Government.

#### **17 Breach, suspension and termination**

17.1 The Authority may, by written notice of suspension to the Contractor, suspend part or all payments to the Contractor hereunder if the Contractor fails to perform any of its obligations

under this Agreement, including the carrying out of the Services, provided that such notice of suspension shall (i) specify the nature of the failure, and (ii) request the Contractor to remedy such failure within a period not exceeding [ ] Business Days after receipt by the Contractor of such notice of suspension. If in the reasonable opinion of the Authority, the Contractor fails to remedy the breach set out in the notice of suspension within [ ] Business Days of service of the notice by the Authority, the provisions of Clause 17.2.4 shall apply.

17.2 Notwithstanding the provisions of Clause 2, and subject to Clause 17.5, the Authority may terminate this Agreement with no less than [ ] Business Days' prior written notice to the Contractor after the occurrence of the events specified in paragraphs 17.2.1, 17.2.2 and 17.2.4 (inclusive) of this Clause, without liability to pay any fees, compensation or damages:

17.2.1 if the Contractor does not remedy a failure in the performance of its obligations under the Agreement after being notified by the Authority in writing specifying the nature of the failure and requesting that it be remedied within no less than [ ] Business Days after the service of the notice by the Authority;

17.2.2 if the Contractor becomes insolvent or bankrupt;

17.2.3 if the Authority in its sole discretion and for any reason, whatsoever, decides to terminate this Agreement in which case sums due to the Contractor shall become payable in full for all time spent up to when the Termination Date; and

17.2.4 if the Authority serves a notice of suspension under Clause 17.1 to which the Contractor does not or is unable or unwilling to respond as provided in Clause 17.1 in which event the Authority shall not be liable to pay the portion of the Contract Price to which the notice of suspension relates.

17.3 Notwithstanding the provisions of Clause 2, and subject to Clause 17.5, the Authority may terminate this Agreement with immediate effect without liability to pay any fees, compensation or damages by written notice to the Contractor if, at any time:

17.3.1 the Contractor commits any serious or repeated breach or non-observance of any of the terms or conditions of this Agreement; or

17.3.2 the Contractor is in the reasonable opinion of the **Authority** grossly negligent or incompetent in the performance of the Services; or

17.3.3 the Contractor is guilty of any act of fraud or dishonesty or acts in any manner which, in the reasonable opinion of the **Authority**, brings or is likely to bring the Contractor and/or the Authority **or the Government** into disrepute and/or is materially adverse to the interests of the Authority or the Government; or

17.3.4 the Contractor makes a resolution for its winding up, makes an arrangement or composition with its creditors or makes an application to a court of competent jurisdiction for protection from its creditors or an administration or winding up order is made or an administrator or receiver is appointed in relation to the Contractor such that in the reasonable opinion of the **Managing Director** the Contractor is no longer able to provide the Services; or

17.3.5 any of the warranties set out in this Agreement being found to be inaccurate, misleading or untrue.

17.4 Notwithstanding the provisions of Clause 2 and subject to the provisions of Clause 17.5, the Contractor may terminate this Agreement with immediate effect without liability to pay any compensation or damages by written notice to the Authority if, at any time:

17.4.1 the Authority commits any serious or repeated breach or non-observance of any of the terms or conditions of this Agreement, and for the avoidance of doubt,

subject to Clause 5.4, a failure to pay the Contract Price or instalments thereof on the due date without justification, will be treated as a serious breach; or

17.4.2 the Authority makes a resolution for its winding up, makes an arrangement or composition with its creditors, or makes an application to a court of competent jurisdiction for protection from its creditors, or an administration or winding up order is made, or an administrator or receiver is appointed in relation to the Authority.

17.5 Neither party will be in breach of this Agreement if there is a **Force Majeure Event that prevents the parties from fulfilling their obligations under this Agreement provided that the party affected has taken all reasonable precautions, due care and reasonable alternative measures, all with the objective of continuing to perform its obligations under this Agreement.** A party that is affected by a Force Majeure Event shall continue to perform its obligations under the Agreement as far as is reasonably practicable and shall take reasonable measures to minimise the consequences of the Force Majeure Event. If either party is unable to perform its duties and obligations under this Agreement as a direct result of a Force Majeure Event, that party shall give written notice to the other of the inability stating the reason in question and in any case no later than 10 Business Days following the Force Majeure Event providing evidence of the nature and cause of such event. The operation of this Agreement (including Clause 17.3) will be suspended during the period (and only during the period) during which the Force Majeure Event continues. Immediately upon the Force Majeure Event ceasing to exist the party relying upon it shall give written notice to the other of this fact. If the Force Majeure Event continues for a period of more than 90 days and substantially affects the parties' ability to perform the terms of this Agreement, the party not claiming relief under this Clause 17.5 will have the right to terminate this Agreement upon giving 30 days' written notice of such termination to the other party.

## 18 **Obligations on termination**

18.1 The Contractor will immediately on the termination of this Agreement for any reason and at the request of the Authority at any time during the Agreement surrender to a person duly authorised by the Authority all computer programs, reports, manuals, files, notes, accounts, documents, correspondence, books, materials, papers and information (on whatever media and wherever located), any keys and any other property of the Authority or the Government or its or their business contacts that have been made or received by the Contractor during the course of providing the Services (whether under the terms of this Agreement or any other agreement or arrangement between the Authority and the Contractor) and which are in the Contractor's possession or under the Contractor's control and which are the property of the Authority **or the Government.**

18.2 Subject to the terms of this Agreement, to the extent that the Agreement terminates prior to the time charges for work performed by the Contractor in respect of the Services exceeding any portion of the Contract Sum paid by the Authority, the Contractor shall immediately upon termination produce to the Authority a detailed breakdown of time charges incurred up to the date of termination for review and approval by the Authority and which shall be in substance acceptable to the Authority, acting reasonably. The Authority shall be entitled to a refund of the portion of the Contract Sum not properly due to the Contractor as soon as reasonably practicable after termination.

18.3 To the extent permitted by applicable law, immediately on the termination of this Agreement for any reason the Contractor will, having first returned the information to the Authority as required by Clause 18.1, irrevocably delete any remaining information

relating to the business of the Authority and/or the Government stored in any magnetic or optical drive or memory and all matter derived from such sources which is in its or their possession or under its or their control and is outside the premises of the Authority, other than any documents required to be maintained by law.

18.4 On the termination of this Agreement, the Contractor will provide a signed statement that it has fully complied with this Clause 18.

**19 Restrictions on assignment/sub-contracting**

The Authority may, without the consent of the Consultant, assign, delegate, sub-contract or otherwise transfer its rights and obligations under this Agreement to the Government or to any company with which it may merge or to any company to which it may transfer its assets and/or undertaking, provided that it gives prior written notice to the Contractor. The Contractor may not assign this Agreement or any of its rights and obligations under it.

**20 Notices**

20.1 Notices under this Agreement shall be in writing and sent to a party's registered office or address as set out on the first page of this Agreement and to the email address set out below. Notices may be given, and shall be deemed received:

20.1.1 by hand delivery, to the place of business of the party being served, on delivery;  
or

20.1.2 by hand delivery, to the registered office of the party being served, on delivery, in either case, with a copy by email in the case of service on the Authority marked for the attention of the Managing Director (Acting), Clive Smith using [clivesmith@bviala.com](mailto:clivesmith@bviala.com) and of the Director of Airport Engineering and Maintenance, Ronnie Lettsume, using [ronnielettsume@bviala.com](mailto:ronnielettsume@bviala.com) and in the case of service on the Contractor marked for the attention of [ ] using [ ] and [ ] using [ ].

**21 Entire agreement**

21.1 The parties agree that this Agreement and any documents entered into pursuant to it, constitutes the entire agreement between them relating to the Services and supersedes all previous agreements, understandings and arrangements between them, whether in writing or oral in respect of its subject matter.

21.2 Each party acknowledges that it has not entered into this Agreement in reliance on, and shall have no remedies in respect of, any representation or warranty that is not expressly set out in this Agreement except in the case of fraudulent misrepresentation. No party shall have any claim for innocent or negligent misrepresentation on the basis of any statement in this Agreement.

21.3 Nothing in this Agreement purports to limit or exclude any liability for fraud.

**22 Further assurance**

Each party shall at the request of the other, and at the cost of the requesting party, do all acts and execute all documents which are necessary to give full effect to this Agreement.

**23 Variation**

No variation of this Agreement shall be valid or effective unless it is in writing, refers expressly to this Agreement and is duly signed or executed by, or on behalf of, each party.

**24 Set off**

Except as expressly set out in this Agreement, each party shall pay all sums that it owes to the other party under this Agreement without any set-off, counterclaim, deduction or withholding of any kind, save as may be provided for by this Agreement or required by law.

- 25 **No partnership or agency**  
Nothing in this Agreement constitutes, or shall be deemed to constitute, a partnership between the parties nor make any party the agent of another party.
- 26 **Remedies and waiver**  
Any remedy or right conferred upon **the Authority** for breach of this Agreement will be in addition to and without prejudice to all other rights and remedies available to **the Authority**. No failure, delay or omission by the Authority or the Contractor in exercising any remedy, right, power or privilege under or in relation to this Agreement will operate as a waiver of that or any other right, power, remedy or privilege of the Authority or the Contractor, nor will any single or partial exercise of any right, power, remedy or privilege preclude any other or further exercise of that or any other right, power, remedy or privilege.
- 27 **Equitable relief**  
Each party recognises that any breach or threatened breach of this Agreement may cause the other party irreparable harm for which damages may not be an adequate remedy. Accordingly, in addition to any other remedies and damages available to the other party, each party acknowledges and agrees that the other party is entitled to pursue the remedies of specific performance, injunction and other equitable relief without proof of special damages.
- 28 **Severability**  
If any provision of this Agreement (or part of any provision) is or becomes illegal, invalid or unenforceable, the legality, validity and enforceability of any other provision of this Agreement shall not be affected.
- 29 **Counterparts**
- 29.1 This Agreement may be executed in any number of counterparts or duplicates each of which shall be an original, but such counterparts or duplications shall together constitute one and the same agreement. This Agreement may be executed by a party's signature transmitted by electronic means, and copies of this Agreement executed and delivered by means of electronic signatures shall have the same force and effect as copies hereof executed and delivered with wet ink signatures. The parties may rely upon electronic signatures as if such signatures were originals.
- 30 **Legal expenses**  
Each party to this Agreement will be responsible for its own legal and other costs and expenses in connection with the negotiation, preparation, execution and implementation of this Agreement.
- 31 **Resolution of disputes**
- 31.1 In the event of any dispute, claim, question or disagreement (the *Dispute*) arising from or relating to this Agreement or the breach thereof, the parties shall use their best efforts to settle the Dispute by negotiation.
- 31.2 If the Dispute cannot be settled through negotiation within 30 days of the beginning of negotiation discussions, the Parties agree to refer the matter to a mutually acceptable mediator. If the Parties cannot agree to the appointment of a mediator within 15 days, the parties will use a mediator appointed by the Chief Executive Officer of the British Virgin Islands International Arbitration Centre (the *BVI IAC*).
- 31.3 Where any dispute, controversy or claim arising out of or relating to this Agreement, or the breach, termination or invalidity thereof is not settled amicably under Clauses 31.1 or 31.2, the parties hereby irrevocably submit to the exclusive jurisdiction of the court of the Virgin Islands.

**32 Governing law**

This Agreement and any dispute or claim arising out of, or in connection with, it, its subject matter or formation (including non-contractual disputes or claims) shall be governed by, and construed in accordance with, the laws of the Virgin Islands.

EXECUTED as a deed by the parties and delivered on the date set out at the head of this Agreement.

Executed as a deed by The BVI Airports Authority Limited acting by Kevin Fahie, Chairman in the presence of Drusilla Fahie, Secretary

\_\_\_\_\_  
Chairman

\_\_\_\_\_  
Secretary

Executed as a deed by [ ] acting by [ ] in the presence of [ ]

\_\_\_\_\_  
Director

\_\_\_\_\_  
Witness

The Schedule  
Part A  
(Scope of Services)

The project will be executed in four key phases:

1.4.1 Site Assessment (Output 1)

- Contractor to conduct a site survey and assessment of the existing lighting and PAPI systems.
- Provide an inception report outlining the issues, methodology and recommendations to complete works including project timelines for each output.

1.4.2 Design and Engineering (Output 2)

1. The contracted vendor is to develop detailed engineering drawings, including:
  - Proposed layout of the new systems.
  - Material, structural, and service specifications.
  - Area tabulations and civil work requirements.

In addition, the vendor must present the design and engineering drawings to BVIAA for approval and make necessary adjustments. This phase requires Factory Acceptance Testing (FAT).

1.4.3 Installation of New Systems (Output 3)

- Transport all system components to the airport.
- Provide a detailed work plan and changeover management documentation.
- Supervise the project with clear timelines and milestones.
- Install and commission the new systems, including control system programming.
- Deliver "as-built" drawings and documentation.

#### 1.4.4 Routine Maintenance Program (Output 4)

Provide a comprehensive maintenance program, including:

- Spare parts stock.
- Maintenance manuals.
- On-site training to equip maintenance staff with the skills to install, maintain, and troubleshoot runway lighting and PAPI systems. This includes system upkeep, electrical and power systems, and control system operation, ensuring reliability and compliance.

Part B  
(Project Delivery Timeline)

Part C  
(Cost Proposal)  
Fees

Arch Length: 60'

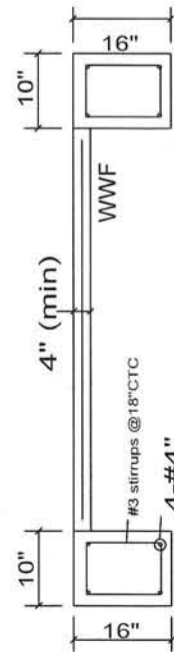
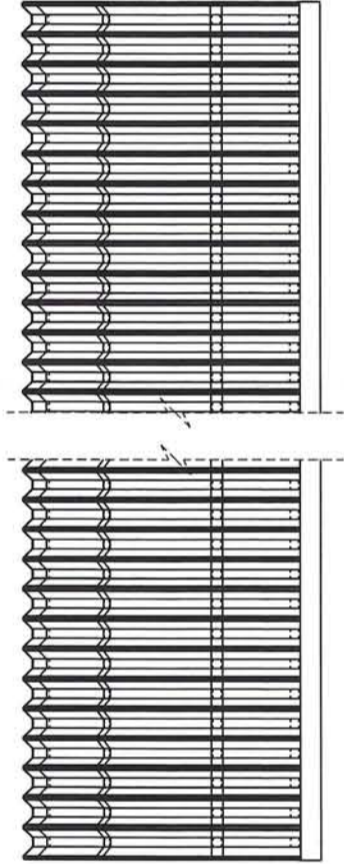
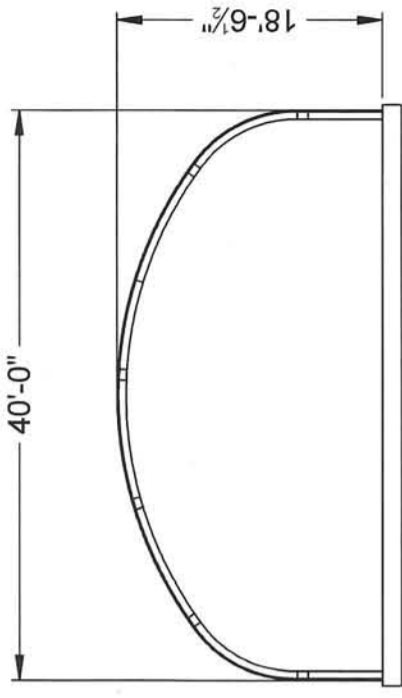
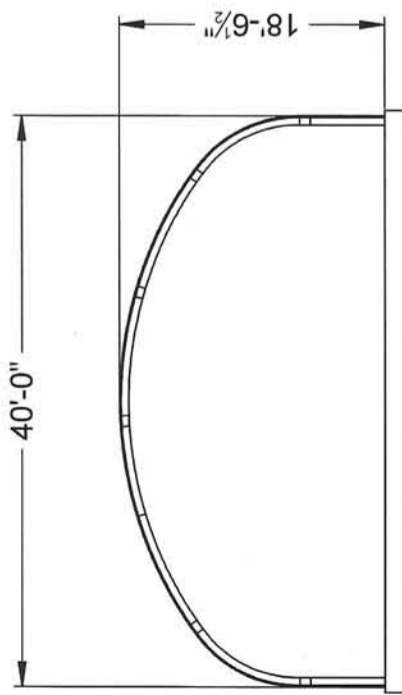

SECTION A-A

SLAB OPTIONAL AT CUSTOMERS DISCRETION

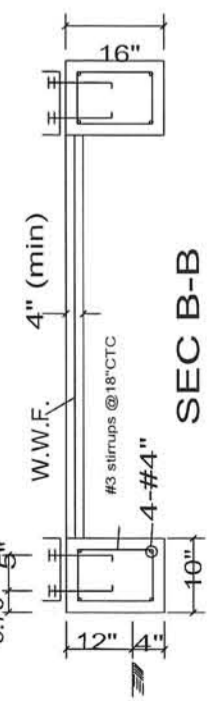

SECTION B-B

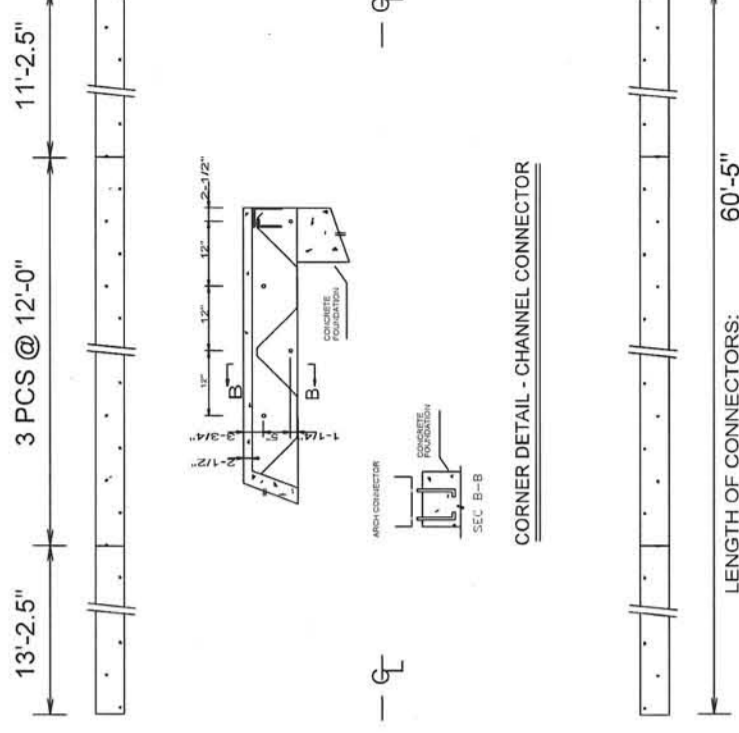
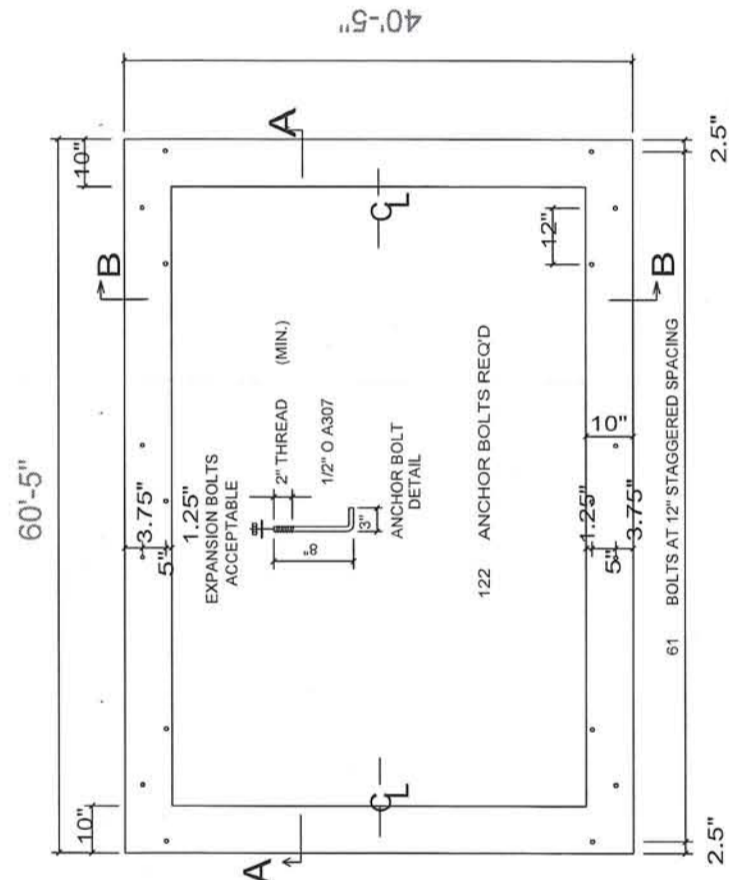

**FOUNDATION NOTES**

1. ALL MATERIAL AND WORKMANSHIP SHALL CONFORM WITH THE REQUIREMENTS OF THE LATEST REVISION OF THE IBC-2024 BUILDING CODE
2. NO LOADS OTHER THAN THOSE GIVEN UNDER "DESIGN DATA" BELOW SHALL BE IMPOSED ON THE "STRUCTURE"
3. THE STRUCTURAL DESIGN OF THIS BUILDING IS BASED ON ASSEMBLY IN EXACT ACCORDANCE WITH ERECTION PLANS & INSTRUCTIONS. FAILURE TO FOLLOW THESE INSTRUCTIONS SHALL BE THE SOLE RESPONSIBILITY OF THE ERECTOR.
4. BUILDING MUST BE GROUTED IN PLACE ONCE THE FOUNDATION IS COMPLETE TO REACH FULL LOADING CAPACITY. BUILDING IS SUBJECT TO COLLAPSE IF NOT FULLY GROUTED ACCORDING TO INSTRUCTIONS.
5. GROUTING NOT NECESSARY IF USING INDUSTRIAL ARCH CONNECTOR.

**DESIGN DATA** (MATERIALS)

1. CONCRETE F<sub>c</sub> = 2500 PSI @ 28 DAYS, ACI
2. REINFORCING STEEL GRADE 40, F<sub>y</sub> = 40 KSI, ASTM A615
3. W.W.F. F<sub>y</sub> = 65 KSI, ASTM A185
4. CONCRETE MIX SHALL CONTAIN 1#/SY FIBER REINFORCING

**ARCH PANEL DATA**

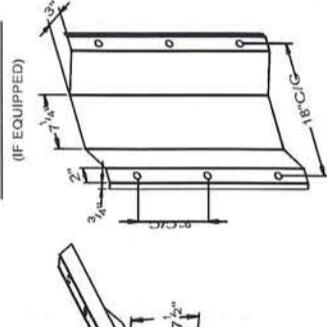

**ENDWALL PANEL DATA** (IF EQUIPPED)



**DESIGN DATA IN ACCORDANCE WITH ANSISASCE 7-10:**

- MINIMUM ROOF LIVE LOAD (PSF) = 35
- P<sub>g</sub> GROUND SNOW LOAD (PSF) = 44
- V WIND VELOCITY (MPH) = 150
- SEISMIC DESIGN CATEGORY = D
- BOLTS: 5/16" X 1 1/2" X 3/4" GRADE 2 SAE OR ASTM A307
- STEEL ROOF PANEL GAUGE = 20 GA
- STEEL ENDWALL PANEL GAUGE = 18 GA
- STEEL SIDEWALL PANEL GAUGE = 18 GA
- STEEL ENDWALL SHEET STEEL GALVALUME

**STRUCTURAL QUALITY ASTM SPECIFICATION**

- 50% ALUMINUM-ZINC ALLOY (HOT DIP COATING)
- ASTM A792 GRADE 50
- 50 KSI MINIMUM YIELD
- 65 KSI MINIMUM TENSILE

**PSGCUSTOM**  
 F A C T O R Y  
 U.S. Buildings  
 355 INDUSTRIAL PARK DRIVE  
 BOONE, NC 28607

DRAWN BY: C APPROVED BY:  
 SCALE: N.T.S CHECKED BY:  
 DATE: 5/13/2025 ORDER NO. 90-34441  
 CUSTOMER: RONNIE LETTSOME  
 PROPERTY ADDRESS: ROAD TOWN  
 CITY, STATE: TORTOLA, BRITISH VIRGIN ISLANDS ZIP:  
 MODEL: S40-18x60 DWG: GENERAL ARRANGEMENT



PROFESSIONAL ENGINEER  
 STATE OF FLORIDA  
 LICENSE NO. 69555  
 ROBERT V. MANGIA  
 HOUSTON, TEXAS 77055

26 2025





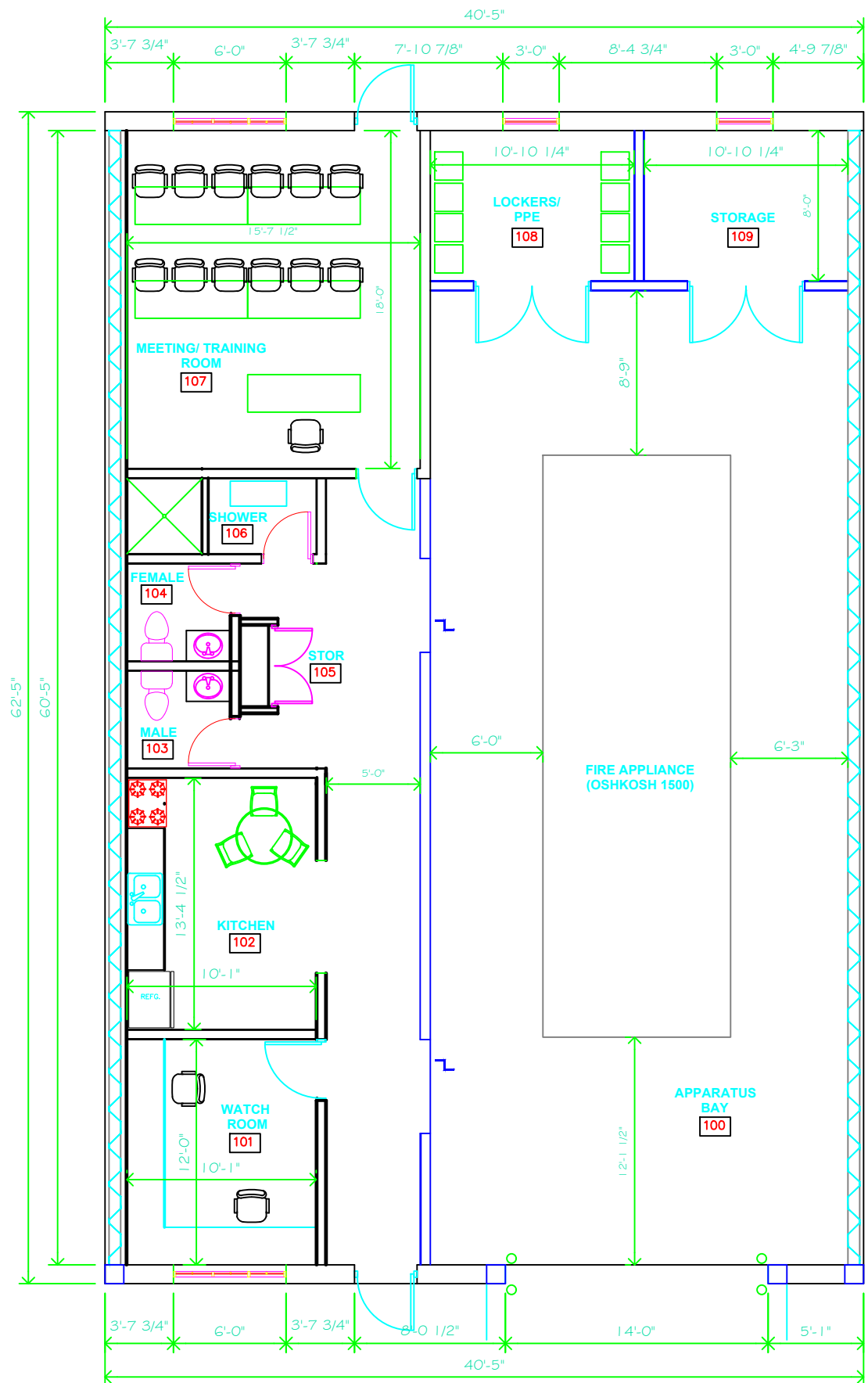

PROPOSED FIRE TENDER SHED TO AUGUSTE GEORGE INTERNATIONAL AIRPORT  
THE SETTLEMENT, ANEGADA, BVI.

**SUMMARY**

REVISED SCOPE: Shell, Steel Erection & Rough-In Only

Ref	Description	Qty	Units	Rate	Value
	PRELIMINARIES				
	CIVIL WORKS				
	CONCRETE WORKS				
	STEEL FRAME BUILDING SHED				
	PLUMBING INSTALLATIONS (ROUGH-IN)				
	ELECTRICAL ROUGH-IN				
	<b>TOTAL WORKS</b>				

PROPOSED FIRE TENDER SHED TO AUGUSTE GEORGE INTERNATIONAL AIRPORT  
THE SETTLEMENT, ANEGADA, BVI.

**PRELIMINARIES**

Ref	Description	Qty	Units	Rate	Value
	<b>Contract Administration</b>				
1	Builder's Risk Insurance		Item		
2	Performance Bond; 10%		Item		
3	Health and Safety Equipment		Item		
	<b>Staff Costs</b>				
4	Site Foreman Supervision		Months		
5	Hire Surveyor to set levels		Item		
	<b>Running Costs</b>				
6	Material Transportation to site		Months		
7	Barge Costs		Item		
8	Site power running costs		Months		
9	Drinking water (water and ice etc.)		Months		
10	Rubbish Disposal and Clean Up		Months		
	<b>Plant and Equipment</b>				
11	Small plant, equipment and accessories		Months		
	<b>To Collection</b>				

PROPOSED FIRE TENDER SHED TO AUGUSTE GEORGE INTERNATIONAL AIRPORT  
THE SETTLEMENT, ANEGADA, BVI.

**CIVIL WORKS**

Ref	Description	Qty	Units	Rate	Value
	<b>HEAVY EQUIPMENT</b>				
	<b>Civil Works</b>				
12	Hire excavator to demolish the existing cross drainage system perpendicular to the runway		Day		
13	Hire excavator with hammer to assist with excavation in rocks.		Day		
14	Hire 20Yd Truck to cart away excavated materials off site arising from demolition of existing cross drainage system		Day		
15	Level and compact existing soil to receive concrete.		SY		
16	Vapour barrier to concrete road way slab, retaining wall and catchment		SF		
	<b>To Collection</b>				

PROPOSED FIRE TENDER SHED TO AUGUSTE GEORGE INTERNATIONAL AIRPORT  
THE SETTLEMENT, ANEGADA, BVI.

**CONCRETE WORKS**

Ref	Description	Qty	Units	Rate	Value
	<b>CONCRETE WORK</b>				
	5000 PSI Reinforced concrete filled into formwork and packed and vibrated around reinforcement in:				
	<b>Foundations &amp; Slab on Grade</b>				
17	Strip Footing		CY		
18	Slab on Grade		CY		
	<b>Shed Structural Frame</b>				
19	Walls, Columns & Beams		CY		
	<b>FORMWORK</b>				
	Formwork and supports to:				
	<b>Foundations &amp; Slab on Grade</b>				
20	Strip Footing		SY		
21	Slab on Grade		SY		
	<b>Shed Structural Frame</b>				
22	Walls, Columns & Beams		SY		
	<b>REINFORCEMENT</b>				
	High yield steel deformed bar reinforcement; rates to include for laps, bends, hooks, tying wire and spacers in:				
	<b>Foundations &amp; Slab on Grade</b>				
	<b>Strip Footing</b>				
23	#4 rebars		Lbs		
24	#5 rebars		Lbs		
	<b>Slab on Grade</b>				
25	#4 rebars		Lbs		
26	6X6 W2.9 X W2.9 WWF Mesh		SY		

PROPOSED FIRE TENDER SHED TO AUGUSTE GEORGE INTERNATIONAL AIRPORT  
THE SETTLEMENT, ANEGADA, BVI.

**CONCRETE WORKS (Continued)**

Ref	Description	Qty	Units	Rate	Value
	<b>Shed Structural Frame</b>				
	<b>Walls, Columns &amp; Beams</b>				
27	#3 rebars		Lbs		
28	#4 rebars		Lbs		
29	#5 rebars		Lbs		
	<b>Sundries</b>				
30	Flashing secured with #12 Tapcon Screws to join steel building with concrete wall structure (Detail S-04 on Sheet S-501)		LF		
31	Allow for anchor bolts into concrete slab		Item		
	<b>To Collection</b>				

PROPOSED FIRE TENDER SHED TO AUGUSTE GEORGE INTERNATIONAL AIRPORT  
THE SETTLEMENT, ANEGADA, BVI.

**STEEL FRAME BUILDING SHED**

Ref	Description	Qty	Units	Rate	Value
	<b>WARE HOUSE BUILDINGS</b>				
	Erection of the Steel Frame Building supplied by Client — Ware House Building 60'-0" long x 40'-0" wide				
32	Labour to erect structural frame/cladding to walls & roof according to Manufacturer's instructions		Item		
33	Hire 28Ton Crane to install structural steel panels		Days		
	<b>Sundries:</b>				
34	Allow for materials and tools required for installation of Structural Panels		Item		
	<b>PROVISIONAL SUM ALLOWANCE</b>				
35	Include a Provisional Sum Allowance for any unforeseen works or changes as instructed by Project Manager		PS		
	<b>To Collection</b>				

PROPOSED FIRE TENDER SHED TO AUGUSTE GEORGE INTERNATIONAL AIRPORT  
THE SETTLEMENT, ANEGADA, BVI.

**PLUMBING INSTALLATIONS**

Ref	Description	Qty	Units	Rate	Value
	<b>PLUMBING WORKS</b>				
	Allow here for the complete Plumbing Rough-in Installation as detailed on the Architect's & MEP Engineer's Drawings and Specification in its entirety.				
64	Complete plumbing rough-in installation to Ground Floor		Item		
65	Allowance for testing & commissioning the complete plumbing installations		Item		
	<b>To Collection</b>				

PROPOSED FIRE TENDER SHED TO AUGUSTE GEORGE INTERNATIONAL AIRPORT  
THE SETTLEMENT, ANEGADA, BVI.

**ELECTRICAL INSTALLATIONS (ROUGH-IN)**

Ref	Description	Qty	Units	Rate	Value
	<b>ELECTRICAL WORKS (ROUGH-IN ONLY)</b>				
	Electrical rough-in as detailed on the Architect's & MEP Engineer's drawings and specification.				
69	Incoming mains cable between main disconnection point at building Exterior to Main Breaker panel(s) point in conduit; 50' Allowed		Ft		
70	Main Breaker Panel		Nr		
77	Allowance for Builder's Work on electrical installations including duct for small power (laid in common services trench) all cutting holes, chases, making good and ensuring work is complete and neatly installed.		Item		
78	Allowance for testing & commissioning the complete electrical installations		Item		
	<b>To Collection</b>				

# STRUCTURAL GENERAL NOTES

## 1.0 LIVE LOADS USED IN DESIGN

- 1.1 ROOF LIVE 20 PSF
- 1.2 TYPICAL FLOOR 100 PSF
- 1.3 WIND DESIGN
  - 1.3.1 WIND VELOCITY 165 MPH V 3S
  - 1.3.2 WIND EXPOSURE D
  - 1.3.3 HURRICANE RATED WINDOWS SHALL RESIST THE FOLLOWING PRESSURES: POSITIVE 75 PSF, NEGATIVE 90 PSF
- 1.4 EARTHQUAKE ZONE 4 (UBC REFERENCE)
  - 1.4.1 SEISMIC DESIGN CATEGORY D
  - 1.4.2 SITE CLASS C/D
  - 1.4.3 SPECTRAL RESPONSE ACCELERATIONS  $S_s$  1.4,  $S_1$  0.47
  - 1.4.4 SPECTRAL RESPONSE COEFFICIENTS  $S_{ds}$  0.84,  $S_{d1}$  0.752
- 1.5 FLOOD DATA: SEE SPECIFIC SITE NOTE

## 2.0 FOUNDATIONS

- 2.1 MAXIMUM SOIL DESIGN PRESSURE (ASSUMED) 3000 PSF
- 2.2 ALL FOOTINGS ARE TO BE PLACED ON FIRM, UNDISTURBED NATURAL GROUND, APPROVED BY THE ENGINEER. SEE SPECIFICATION FOR INFORMATION ON PILED FOUNDATIONS.
- 2.3 DO NOT PLACE BACKFILL AGAINST BASEMENT WALLS UNTIL BASEMENT AND FIRST FLOORS ARE IN PLACE.
- 2.4 CENTER ALL FOOTINGS UNDER WALLS, COLUMNS OR GRID LINES UNLESS OTHERWISE NOTED IN THE DRAWINGS

## 3.0 CONCRETE

- 3.1 ALL CAST-IN-PLACE CONCRETE SHALL BE MADE WITH TYPE-2 PORTLAND CEMENT, STONE AGGREGATE AND SHALL DEVELOP 5000 PSI COMPRESSIVE STRENGTH IN 28-DAYS.
- 3.2 SLABS, TOPPING, FOOTINGS BEAMS AND WALLS SHALL NOT HAVE JOINTS IN HORIZONTAL PLANE. ANY STOP IN CONCRETE WORK MUST BE MADE AT CENTER OF SPAN WITH VERTICAL BULKHEADS AND SHEAR KEYS, UNLESS OTHERWISE SHOWN. ALL CONSTRUCTION JOINTS SHALL BE AS DETAILED OR AS APPROVED BY THE ENGINEER. SEE NOTE 4.0 BELOW.
- 3.3 ALL CONCRETE WORK AND REINFORCEMENT DETAILING SHALL BE IN ACCORDANCE WITH ACI BUILDING CODE 318-19. ALL EXPOSED EDGES OF CONCRETE WORK SHALL HAVE 1/2" MIN. CHAMFER. USE STANDARD HOOKS ON DOWELS UNLESS OTHERWISE NOTED.
- 3.4 MIXING, PLACING AND CURING OF ALL CONCRETE TO BE BY THE RECOMMENDATIONS IN ACI 305R-20, HOT WEATHER CONCRETING.
- 3.5 ALL CONCRETE SHALL BE MADE WITH GRACE DCI S CORROSION PROTECTING ADMIXTURE (EXCEPT CISTERN WALLS AND CISTERN GROUND SLABS) IN ACCORDANCE WITH THE MANUFACTURER'S SPECIFICATIONS.
- 3.6 PLACE JOINTS IN SLABS ON GRADE TO CREATE AREAS NO GREATER THAN 400 SQ. FT. COORDINATE JOINT LOCATIONS W/ ARCHITECT TO MINIMISE IMPACT ON FLOOR FINISH. SAW CUTS CAN BE USED BUT MUST BE MADE WITHIN 3 HOURS OF PLACEMENT OF THE SLAB.
- 4.0 REINFORCEMENT
  - 4.1 ALL REINFORCEMENT SHALL BE HIGH STRENGTH DEFORMED BARS CONFORMING TO ASTM A615-20 GRADE 60, EXCEPT TIES, STIRRUPS AND PLATE ANCHORS, WHICH SHALL BE ASTM DESIGNATION A615 / A615M - 20, GRADE 40 STEEL.
  - 4.2 WELDED WIRE FABRIC SHALL CONFORM TO ASTM A185-07 AND SHALL BE LAPPED ONE FULL MESH AT SIDES AND END SPLICES AND WIRE TOGETHER.
  - 4.3 CONCRETE PROTECTION FOR REINFORCEMENT (REBAR-COVER)
    - 4.3.1 CONCRETE CAST AGAINST EARTH AND PERMANENTLY EXPOSED TO EARTH 3"
    - 4.3.2 CONCRETE CAST IN FORMS AND EXPOSED TO EARTH OR WEATHER 2"
    - 4.3.3 CONCRETE NOT EXPOSED TO EARTH OR WEATHER SLABS AND WALLS 1-1/2" BEAMS AND COLUMNS - PRIMARY REINFORCEMENT, TIES, STIRRUPS AND SPIRALS 1-1/2"
  - 4.4 ALL BAR LENGTHS ARE DRAWN TO SCALE UNLESS OTHERWISE NOTED. NO SPLICES OF REINFORCEMENT SHALL BE MADE EXCEPT AS DETAILED OR AUTHORIZED BY THE ENGINEER. LAP SPLICES WHERE PERMITTED SHALL BE A MINIMUM OF 48 BAR DIAMETERS. MAKE ALL BARS CONTINUOUS AROUND CORNERS AND ALL RECTANGULAR OPENINGS IN CONCRETE.

- 4.5 PLACE #5 BAR (1-QTY PER 6" THICKNESS) WITH 2'-0" PROJECTION AROUND ALL OPENINGS IN SLABS OR WALLS. ALSO PROVIDE 1- #5 x 4'-0" DIAGONALLY AT EACH CORNER.
- 4.6 CONTINUOUS TOP AND BOTTOM BARS IN WALLS AND BEAMS SHALL BE SPICED AS FOLLOWS:
  - 4.6.1 TOP BARS AT MID-SPAN
  - 4.6.2 BOTTOM BARS OVER SUPPORTS
- 4.7 PROVIDE ALL ACCESSORIES NECESSARY TO SUPPORT REINFORCEMENT AT POSITIONS SHOWN IN THE DRAWINGS. ALL REINFORCEMENT TO BE HELD SECURELY IN PROPER POSITION IN ACCORDANCE WITH ACI 318-19. ALL ACCESSORIES TO BE GALVANIZED.
- 4.8 ANY WELDED REINFORCING BARS SHALL CONFORM TO ASTM A706 OR A615, GRADE 60 AND ANSI / AWS D1.4-18.
- 4.9 ALL TIES AND STIRRUPS SHALL BE 135° SEISMIC HOOKS IN ACCORDANCE WITH ACI 318-19

## 5.0 MASONRY

- 5.1 NOT USED

## 6.0 STRUCTURAL STEEL

- 6.1 ALL STRUCTURAL STEEL SHALL CONFORM TO ASTM SPECIFICATION A992 GRADE 50 EXCEPT PIPE COLUMNS WHICH SHALL CONFORM TO ASTM A53, AND TUBE COLUMNS TO ASTM A500, LATEST EDITIONS. ANCHOR BOLTS SHALL BE A307 STEEL AND MISCELLANEOUS EMBEDDED ITEMS SHALL BE A36 STEEL.
- 6.2 ALL STRUCTURAL STEEL SHALL BE DETAILED AND FABRICATED IN ACCORDANCE WITH THE LATEST PROVISIONS OF AISC "STEEL CONSTRUCTION MANUAL". USE A325 BOLTS AND E60XX-SMAW WELD ROD FOR CONNECTIONS UNLESS OTHERWISE NOTED.
- 6.3 UNLESS OTHERWISE NOTED, USE STANDARD BEAM SEAT CONNECTIONS WITH STEEL BOLTS OR WELDED EQUIVALENT. SELECT CONNECTIONS AT EACH SPLICE TO SUPPORT 60% THE TOTAL UNIFORM LOAD CAPACITY FOR EACH GIVEN BEAM AND SPAN. USE A325 BOLTS UNLESS OTHERWISE NOTED.
- 6.4 MINIMUM WELDS TO BE BY AISC AND/OR AWS BUT NOT LESS THAN 3/16" CONTINUOUS FILLET UNLESS OTHERWISE NOTED.
- 6.5 PROVIDE ANCHORS FOR BEAMS BEARING ON MASONRY WHERE ANCHOR BOLTS ARE NOT SPECIFIED. SEE ARCHITECTURAL AND MECHANICAL DRAWINGS FOR NAILER HOLES, SPECIAL DETAILS AND MISCELLANEOUS STEEL.
- 6.6 PROVIDE TEMPORARY BRACING AND PRECAUTIONS NECESSARY TO WITHSTAND ALL CONSTRUCTION AND/OR WIND LOADS UNTIL ALL FIELD CONNECTIONS ARE COMPLETED AND SHEAR WALLS AND DECKS ARE IN PLACE.
- 6.7 STEEL JOISTS SHALL BE DESIGNED, FABRICATED AND ERECTED IN ACCORDANCE WITH STEEL JOIST INSTITUTE SPECIFICATIONS AND SHALL BE OF THE TYPE SHOWN IN THE DRAWINGS.
- 6.8 PROVIDE COMPRESSION FLANGE BRACING TO ALL PURLINS, GIRTS AND SIMILAR FRAMING MEMBERS AT MIDSPAN ON MEMBERS UP TO 20 FT AND AT 1/3 POINTS ON MEMBERS BETWEEN 20 FT AND 30 FT.

## 7.0 METAL DECK

- 7.1 DECK SHALL BE GALVANIZED STEEL C90 AND OF THE TYPE CALLED FOR ON THE FRAMING PLANS AND SHALL BE CONTINUOUS WHERE POSSIBLE. STEEL SHALL CONFORM TO ASTM A1008/ A1008M.
- 7.2 DECKING SHALL BE INSTALLED AND ALL OPENINGS IN DECKS CUT AND REINFORCED IN ACCORDANCE WITH MANUFACTURER'S STANDARD DETAILS AND SDI SPECIFICATIONS.
- 7.3 FASTENER REQUIREMENTS SHALL BE AS FOLLOWS, UNLESS OTHERWISE SHOWN IN THE DRAWINGS:
  - 7.3.1 LONGITUDINAL JOINTS BETWEEN ADJACENT ROOF DECKS SHALL BE FASTENED TOGETHER WITH WELDS OR #12 TEK SCREWS AT 12". ROOF DECK ATTACHMENT SHALL BE 36/7 AT EAVES AND RIDGE AND 36/5 ELSEWHERE. USE 1/4" TEK SCREWS.
  - 7.3.2 ATTACH FLOOR DECK (PERMANENT CONCRETE FORM) TO EACH INTERMEDIATE SUPPORT W/ 5/8" PUDDLE WELD IN 36/4 PATTERN. EACH END LAP TO BE WELDED AT 10" O.C. EACH SIDE LAP IS WELDED AT EACH END PLUS TWO INTERMEDIATE WELDS (4 WELDS PER SHEET PER SIDE). USE 5/8" PUDDLE WELD AND WASHERS.
- 7.4 ALL CUT EDGES OF METAL DECKING SHALL BE SUITABLY SEALED OR COATED TO PROVIDE CORROSION PROTECTION.

## 8.0 LIGHT - GAGE METAL FRAMING

- 8.1 LIGHT-GAGE METAL FRAMING SHALL BE GALVANIZED G90 ACCORDING TO ASTM A653/ A653M AND OF THE SIZE AND GAGE SHOWN ON THE DRAWINGS.
- 8.2 FRAMING ROLLED FROM STEEL - 18 GAGE AND LIGHTER SHALL CONFORM TO ASTM A653/ A653M, GRADE A, WITH A MINIMUM YIELD STRESS OF 33,000 PSI.
- 8.3 FRAMING FROM STEEL - GAGE 16 AND HEAVIER SHALL CONFORM TO ASTM A653/ A653M, GRADE D WITH A MINIMUM YIELD STRESS OF 56,000 PSI.
- 9.0 DRY PACKING AND NON-SHRINK GROUT
  - 9.1 DRY PACK OR NON-SHRINK GROUT SHALL BE PROVIDED AS FOLLOWS:
    - 9.1.1 BETWEEN COLUMNS BASES AND FOOTINGS
    - 9.1.2 MATERIAL SHALL MEET ASTM C1107/ C1107M AND BE NON-METALLIC
    - 9.1.3 CURE MATERIAL 3-DAYS MINIMUM, BEFORE APPLICATION OF ANY SUPERIMPOSED LOADS.

## 10.0 TIMBER

- 10.1 ALL STRUCTURAL TIMBER SHALL BE SOUTHERN YELLOW PINE NO. 1 OR BETTER UNLESS SHOWN OTHERWISE. MINIMUM BENDING STRESS 1200 PSI, MODULUS OF ELASTICITY 1600 KSI AND SERVICE MOISTURE CONTENT OF NO MORE THAN 19%.
- 10.2 ALL STRUCTURAL PLYWOOD SHALL BE PRESSURE TREATED STRUCTURAL 1 EXTERIOR GRADE.
- 10.3 PROVIDE FULL DEPTH BLOCKING AT 8 FT CENTERS MAXIMUM FOR ALL FLOOR SPANS OVER 8 FT.
- 10.4 PROVIDE DOUBLE 2" x4" PURLINS AT EAVES AND RIDGE.
- 10.5 TONGUE AND GROOVE DECKING SHALL BE ATTACHED WITH 2 #7 SCREWS x 2 1/2" LONG EACH BOARD AT EACH RAFTER. TONGUES FACING UP THE SLOPE.
- 10.6 PLYWOOD SHALL BE ATTACHED TO TONGUE AND GROOVE DECKING WITH #10 SCREWS x 2 1/2" LONG @ 6" O/C ALONG EDGES AND 12" O/C AT INTERMEDIATE RAFTERS. STAGGER PLYWOOD EDGES RUNNING PARALLEL TO RAFTERS.
- 10.7 BUILDING FELT SHALL BE LAID PARALLEL TO THE EAVES WITH A MINIMUM 2' END LAP AND 6" LAP BETWEEN LAYERS.
- 10.8 PURLINS SHALL BE ATTACHED THROUGH DECKING TO RAFTERS WITH #12 x 5" SCREWS TWO PER PURLIN AT EACH RAFTER.
- 10.9 METAL ROOFING SHALL BE 24GA MINIMUM AND ATTACHED TO PURLINS WITH #14 SCREWS 21/4" LONG AT 4" O/C ALONG RIDGE, EAVES, GABLE AND HIPS AND AT 8" O/C ELSEWHERE. AROUND THE PERIMETER OF THE BUILDING AND AT HIPS AND RIDGES, SCREWS SHALL BE AT EACH CORRUGATION IN A STAGGERED PATTERN ENGAGING BOTH OF THE DOUBLED PURLINS. OVERLAP CORRUGATED METAL PANELS AT LEAST 2 CORRUGATIONS ALONG SEAM AND APPLY A BEAD OF CALK AT THE OVERLAP.
- 10.10 USE GALVANIZED ROOFING SCREWS WITH NEOPRENE WASHERS ONLY AT RIDGES OF CORRUGATION
- 10.11 JOIN DOUBLE AND TRIPLE MEMBERS WITH MIN. 5/8" Ø BOLTS @ 24" O.C. UNLESS STATED OTHERWISE

## 11.0 GENERAL

- 11.1 IF ANY CONDITIONS VARY FROM THE DRAWINGS OR THE CONTRACTOR REQUIRES FURTHER CLARIFICATION, ASK THE ARCHITECT AND SITE ENGINEER TO VERIFY. DO NOT PROCEED W/ ANY WORK WITHOUT AGREEMENT BETWEEN THE ARCHITECT AND SITE ENGINEER.
- 11.2 ENGINEER'S APPROVAL MUST BE SECURED FOR ALL STRUCTURAL SUBSTITUTIONS.
- 11.3 PRIOR TO INSTALLATION OF MECHANICAL AND ELECTRICAL EQUIPMENT OR OTHER ITEMS TO BE ATTACHED TO THE STRUCTURE, ENGINEER'S APPROVAL OF CONNECTIONS AND SUPPORTS SHALL BE OBTAINED. UNLESS OTHERWISE SPECIFICALLY DETAILED ON ARCHITECTURAL AND STRUCTURAL DRAWINGS, RESPECTIVE SUBCONTRACTOR SHALL FURNISH ALL HANGERS, CONNECTIONS, ETC. REQUIRED FOR INSTALLATIONS OF HIS ITEMS.
- 11.4 PROVIDE ALL EMBEDDED ITEMS IN STRUCTURE AS NOTED ON ARCHITECTURAL, MECHANICAL, ELECTRICAL AND STRUCTURAL DRAWINGS. MISCELLANEOUS EMBEDDED ITEMS AND ANCHOR BOLTS SHALL BE FURNISH BY STEEL SUPPLIER AND INSTALLED BY CONTRACTOR.
- 11.5 PROVIDE ASPHALTIC MASTIC COATINGS ON ALL STEEL EXPOSED TO THE EARTH.
- 11.6 SUBMIT SHOP AND ERECTION DRAWINGS FOR ALL REINFORCING, STEEL JOIST, STRUCTURAL STEEL AND METAL DECK TO ENGINEER FOR WRITTEN APPROVAL. THE MANUFACTURE OR FABRICATION OF ANY ITEMS PRIOR TO WRITTEN APPROVAL OF SHOP DRAWINGS SHALL BE AT ENTIRELY THE RISK OF THE CONTRACTOR.
- 11.7 ALL MAJOR STEEL AND STEEL JOIST SHOP DRAWINGS SUBMITTED SHALL INCLUDE CALCULATIONS AND BEAR THE STAMP OF A REGISTERED PROFESSIONAL ENGINEER.
- 11.8 CONTRACTOR TO VERIFY ALL DIMENSIONS BEFORE PROCEEDING WITH ANY WORK. DO NOT SCALE FROM DRAWINGS.
- 11.9 PLACE ALL CONDUIT AND SERVICES UNDER ALL SLABS ON GRADE. WHERE CONDUIT AND SERVICES ARE IN BEAMS, COLUMNS AND SUSPENDED SLABS ENSURE THAT MINIMUM COVER OF 1-1/2" TO ALL REINFORCEMENT IS MAINTAINED. DO NOT BUNDLE CONDUIT IN SLABS.

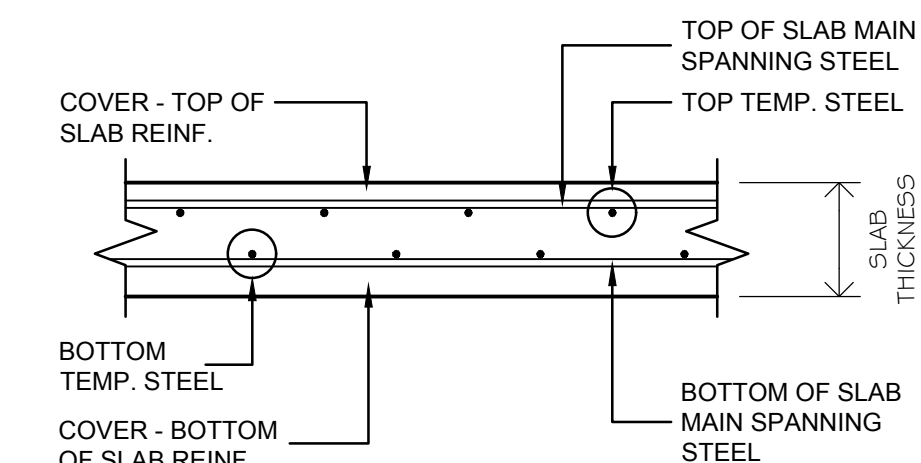

## 11.10 REINFORCEMENT LAYOUT DESIGNATION

11.11 TYPICAL LINTELS. SMALL SPAN LINTELS ARE DEFINED AS HORIZONTAL SIMPLY SUPPORTED ELEMENTS SUPPORTING NO MORE THAN 4-FT OF 8" CMU MASONRY IN AN INTERIOR OR EXTERIOR AXIAL CONDITION AND NOT SUBJECT TO TORSION OR ASYMMETRIC LOADING.

LINTEL	SIZE		REINFORCEMENT			SPAN (MAX.)
	WIDE	DEPTH	BOT.	TOP	TIES	
L-01	6"	12"	1 - #5	1 - #5	#3 @ 4" O.C.	5 FT
L-02	8"	12"	2 - #5	2 - #5	#3 @ 4" O.C.	5 FT
L-03	8"	12"	3 - #5	3 - #5	#3 @ 4" O.C.	10 FT

## ABBREVIATIONS AND SYMBOLS

4 - #5	REBAR DESIGNATION IN A BEAM. QTY = 4 NO. BARS, #5 = 5/8" (INCH) DIAMETER
C-02	COLUMN REFERENCE NUMBER
CONC.	CONCRETE
DET#	DETAIL REFERENCE NUMBER
DIA.	DIAMETER
EA.	EACH
E.W.	EACH WAY
F-04	FOOTING REFERENCE NUMBER
HORIZ.	HORIZONTAL
O.C.	ON CENTER
QTY	QUANTITY
REINF.	REINFORCING OR REINFORCEMENT
SSL : -	STRUCTURAL SLAB LEVEL
TEMP. STEEL	TEMPERATURE AND SHRINKAGE STEEL
VERT.	VERTICAL
W/	WITH
W12X256	WIDE FLANGE BEAM. STRUCTURAL BEAM
WWF.	WELDED WIRE FABRIC = STRUCTURAL MESH



DETAIL MARK / SECTION CUT

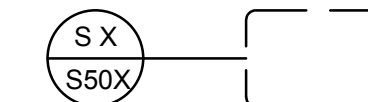

DETAIL REFERENCE BUBBLE

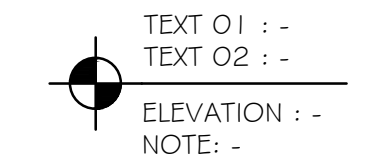

DATUM TAG



SPOT LEVEL TAG



COLUMN / FOOTING DESIGNATION

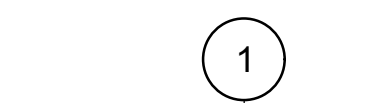

GRID TAGS



STANDARD DIMENSION FORMAT

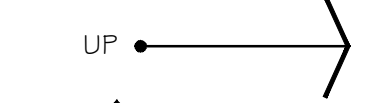

RAMP / STAIR ARROW UP

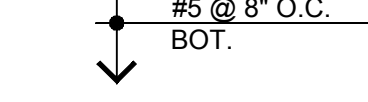

PRIMARY AND TEMPERATURE STEEL DESIGNATION - BOLD FONT

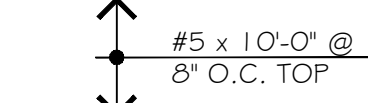

TOP STEEL DESIGNATION - NOTES FONT

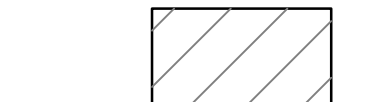

FLOOR SLAB ON GRADE - TYPICAL FORMAT (SPECIFIC NOTE) X" THICK CONC. SLAB (TYPE) WWF IN CENTER OF SLAB

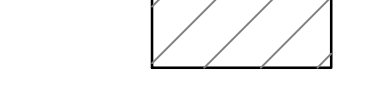

CISTERN SLABS - TYPICAL FORMAT (SPECIFIC NOTE) X" THICK CONC. SLAB (TYPE) WWF IN CENTER OF SLAB

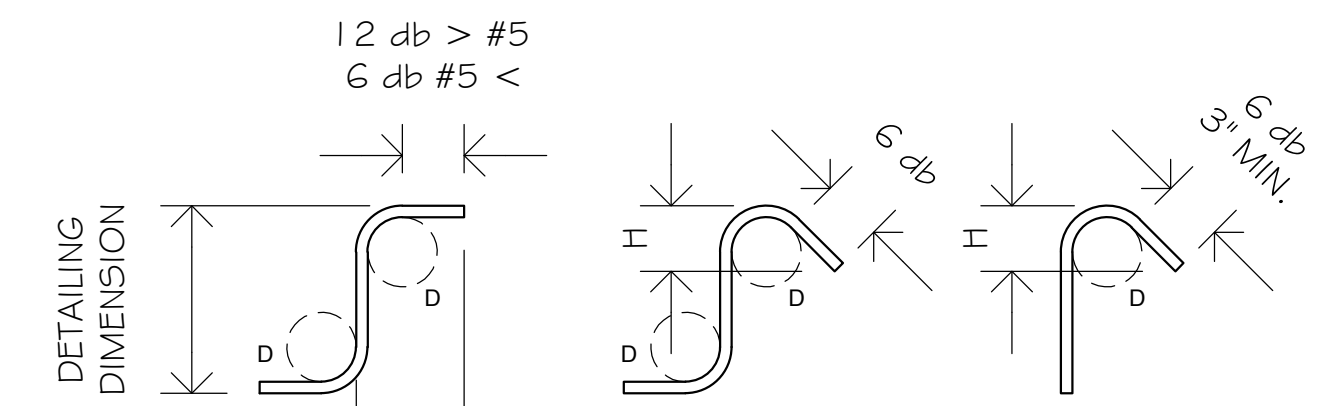

BAR SIZE	D	90° HOOK		135° HOOK		SEISMIC STIRRUP/TIE	
		A OR G	A OR G	A OR G	H	A OR G	H
# 3	1-1/2"	4"	4"	3"	4-1/4"	3"	
# 4	2"	4-1/2"	4-1/2"	4"	4-1/2"	3"	
# 5	2-1/2"	6"	5-1/2"	5"	5-1/2"	3-3/4"	
# 6	4-1/4"	12"	8"	6"	8"	4-1/2"	
# 7	5-1/4"	14"	9"	7"	9"	5-1/4"	
# 8	6"	16"	10-1/2"	8"	10-1/2"	6"	

## STIRRUPS AND TIES

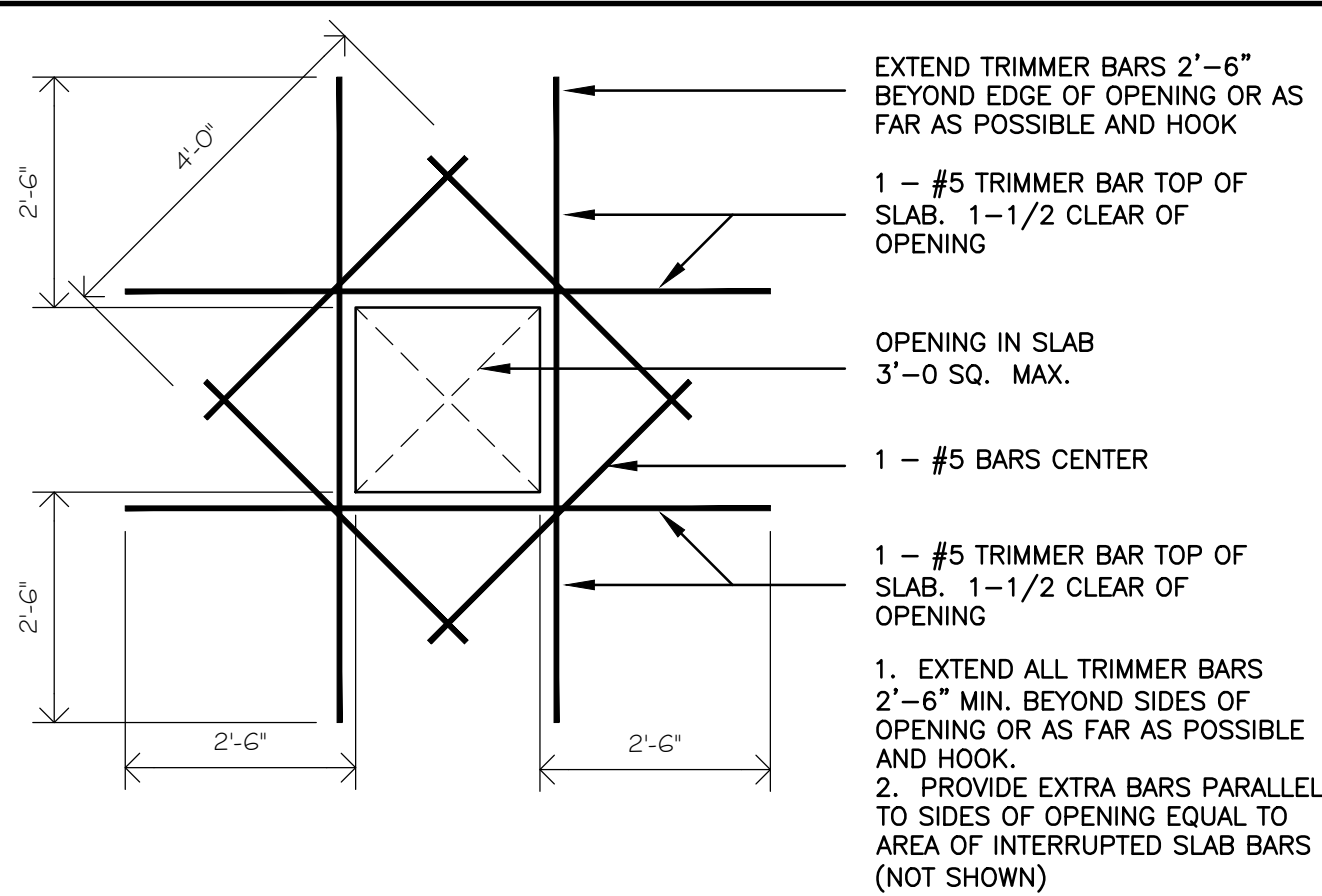

## OPENING IN SLABS

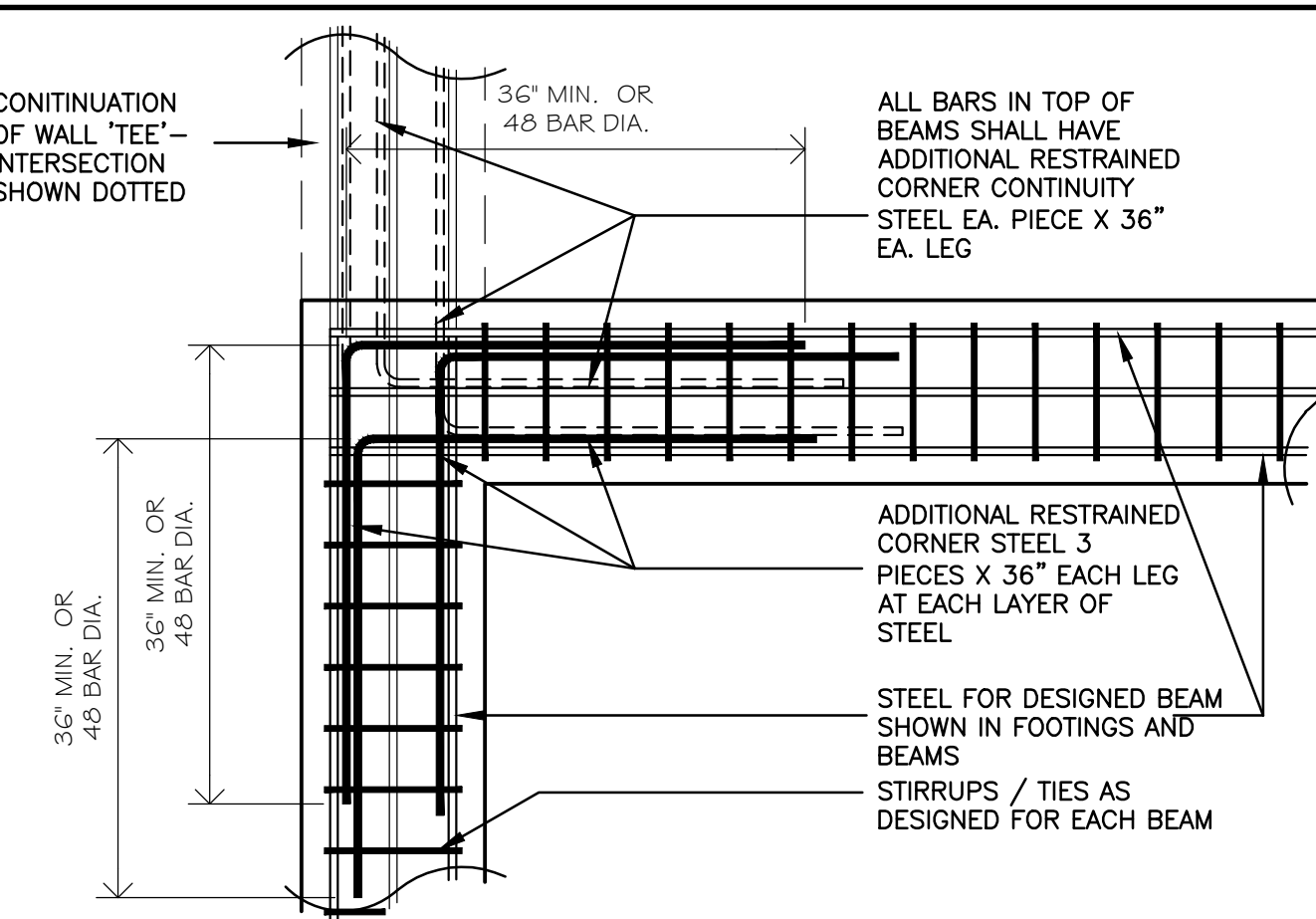

## PLAN: RESTRAINED CORNER AND 'TEE'

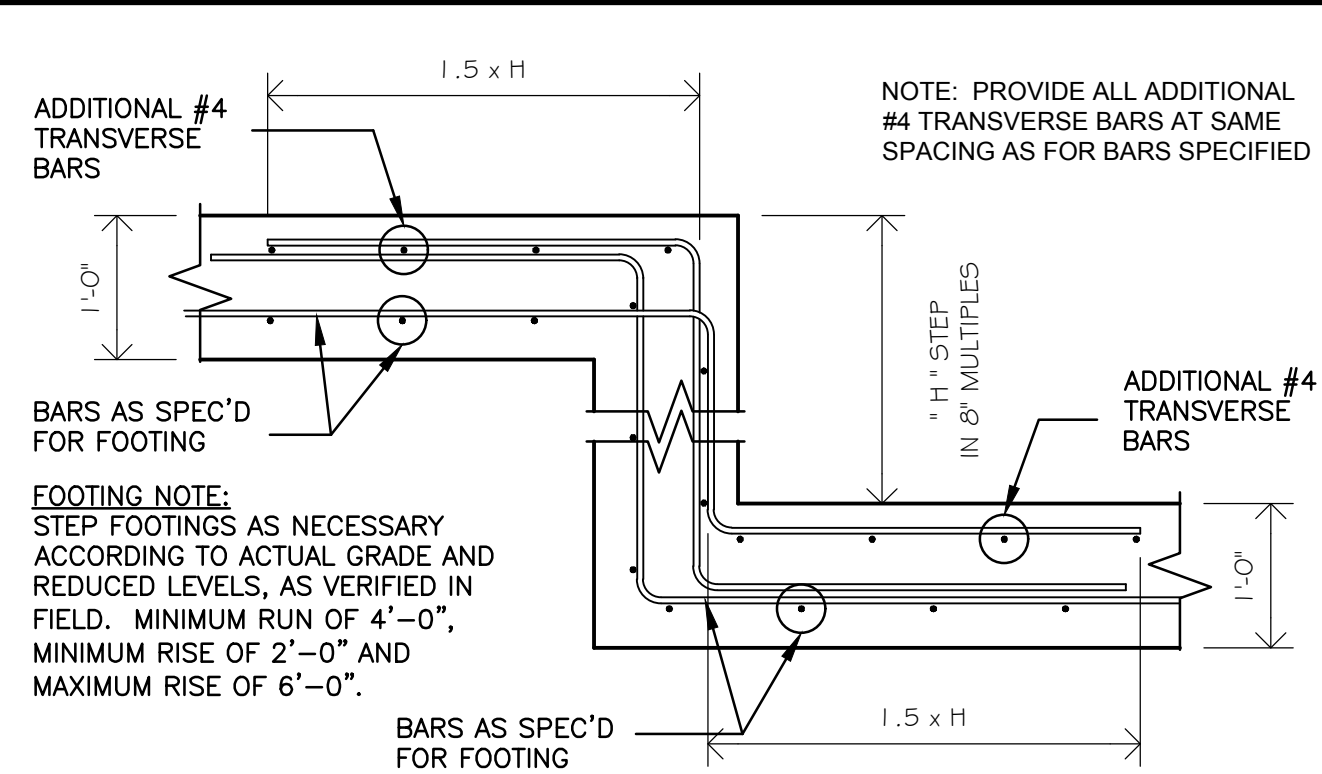

## PROFILE OF FOOTING

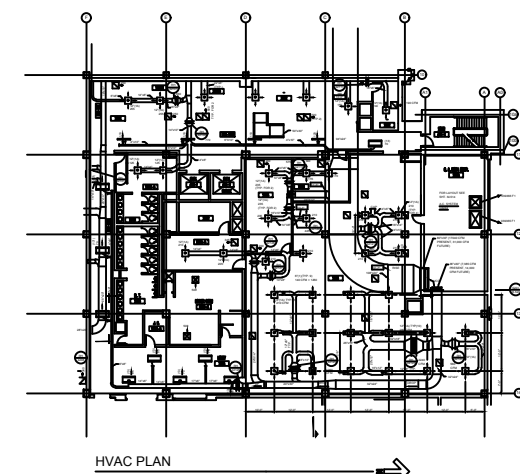

SYSTEMS ENGINEERING LTD.  
P.O. BOX 3891  
SEA COWS BAY  
TORTOLA, VG 1110, B.V.I.  
TEL: 284.494.2987  
FAX: 284.494.0775  
EMAIL: systmeng@surfbvi.com

## NOTES

- 01 DO NOT USE THIS DRAWING FOR CONSTRUCTION UNLESS THE WORDS "CONSTRUCTION SET" APPEARS IN THE REVISIONS COLUMN
- 02

ANEGADA FIRE STATION METAL BUILDING

THE SETTLEMENT ANEGADA BVI

FOR CONSTRUCTION

01	FOR CONSTRUCTION	MT	281128
A	PRELIM. ISSUE TO ARCH.	MT	281013
REV #	DESCRIPTION	DWN	YYMMDD

## ISSUE INFORMATION.

01

DESIGNER: RT

DRAWN: BM

JOB REF:

DATE: 25 10 13

SCALE: AS NOTED

DWG NAME: STRUCTURAL NOTES

DWG NO: S-001

VERS. 5.1 - 081226

# STRUCTURAL NOTES

SCALE : N/A

# STEPPED FOOTING - TYPICAL SCALE: N/A

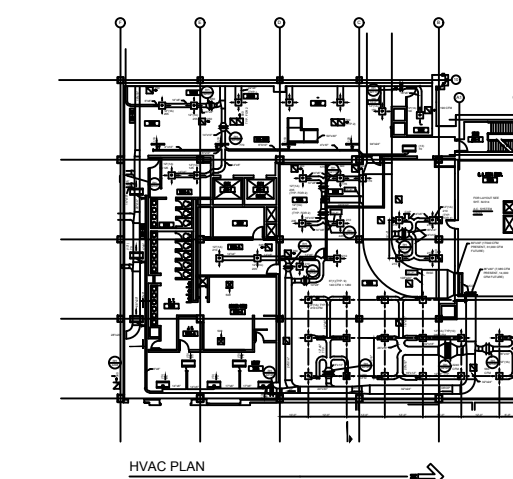
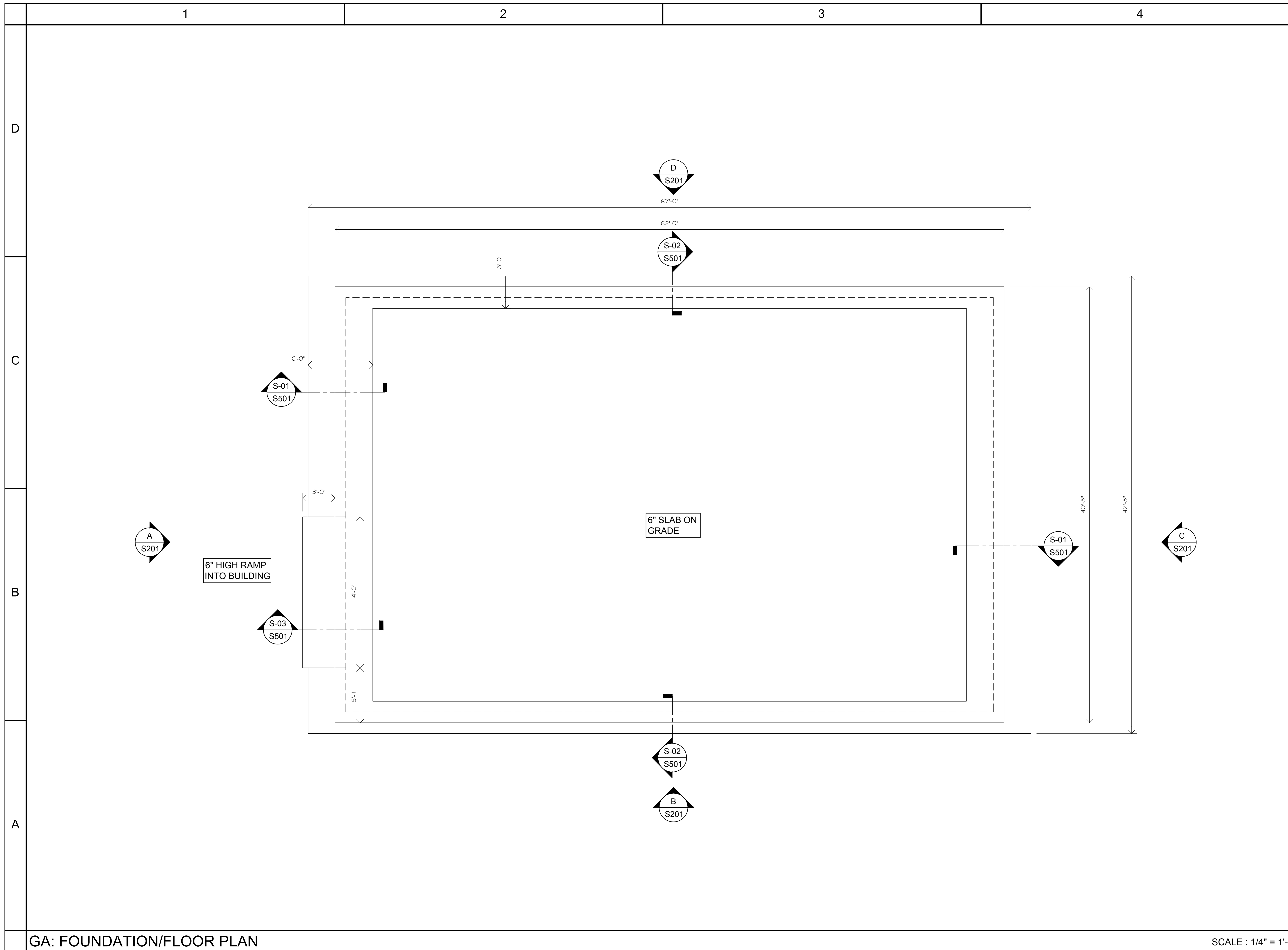

SYSTEMS ENGINEERING LTD.  
 P.O. BOX 3891  
 SEA COWS BAY  
 TORTOLA, VG 1110, B.V.I.  
 TEL: 284.494.2987  
 FAX: 284.494.0775  
 EMAIL: sytmeng@systemscuribbean.com

**NOTES**

- 01 DO NOT USE THIS DRAWING FOR CONSTRUCTION UNLESS THE WORDS "CONSTRUCTION SET" APPEARS IN THE REVISIONS COLUMN
- 02

**ANEGADA FIRE STATION METAL BUILDING:**

THE SETTLEMENT  
 ANEGADA  
 BVI

**FOR CONSTRUCTION**

REV #	DESCRIPTION	DWN	YYMMDD
01	FOR CONSTRUCTION	MT	25 11 28
A	PRELIM. ISSUE TO ARCH.	MT	25 10 13

ISSUE INFORMATION: **01**

DESIGNER: RT

DRAWN: BM

JOB REF:

DATE: 25 10 13

SCALE: AS NOTED

DWG NAME:  
**FOUNDATION/FLOOR PLAN**

DWG NO:  
**S-101**

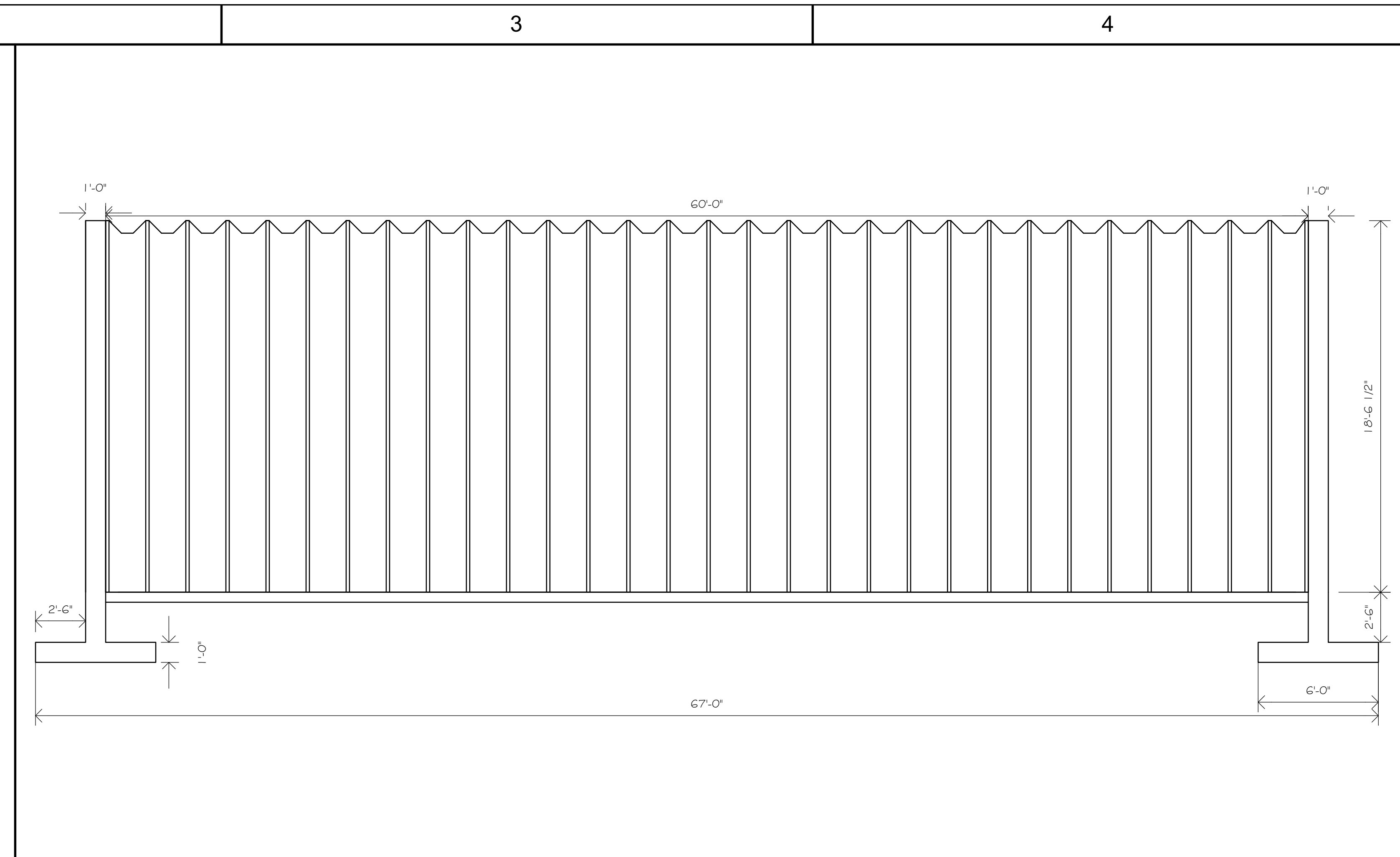
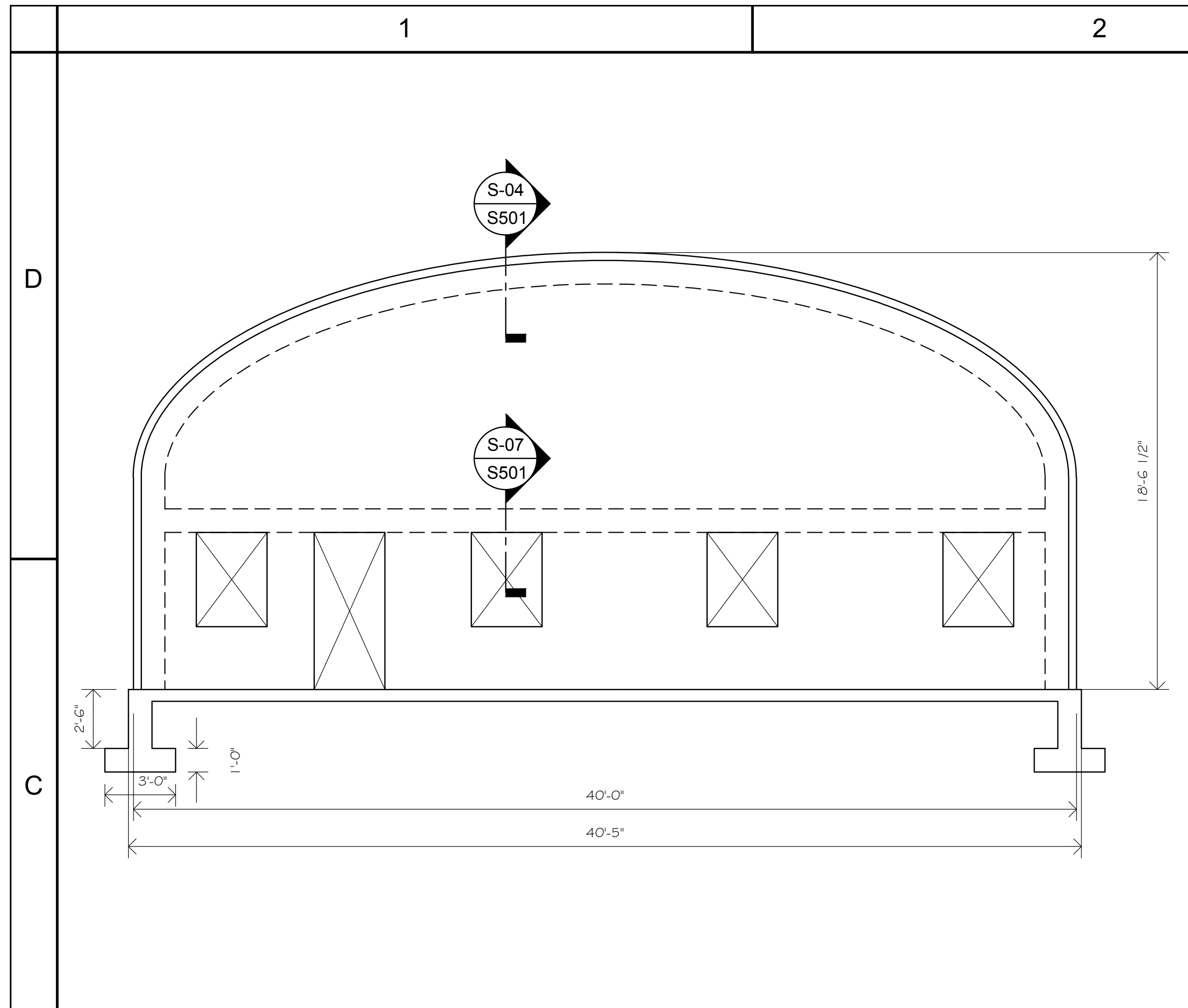

ELEVATION C

SCALE : 1/4" = 1'-0"

ELEVATION D

SCALE : 1/4" = 1'-0"

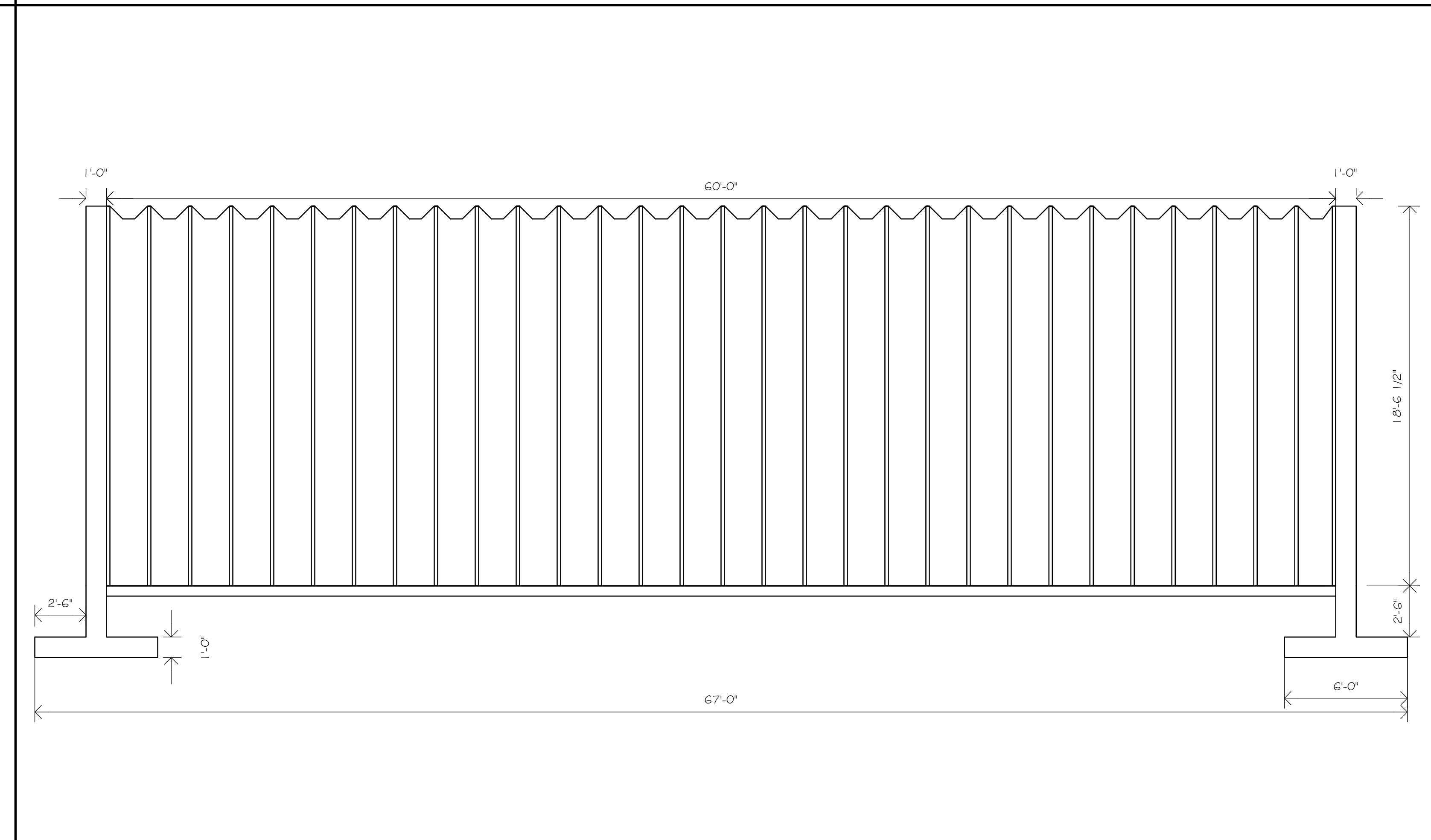
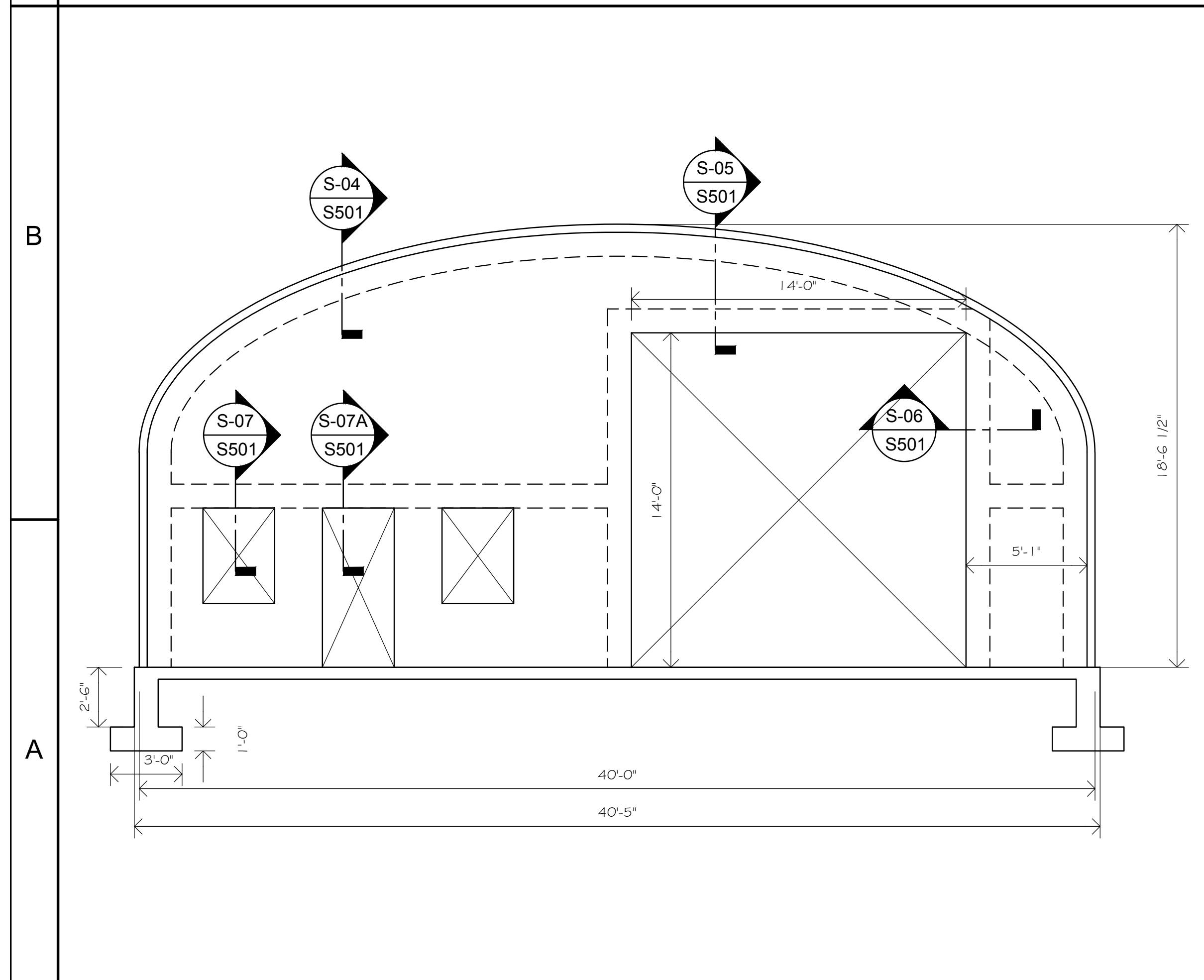

ELEVATION A

SCALE : 1/4" = 1'-0"

ELEVATION B

SCALE : 1/4" = 1'-0"

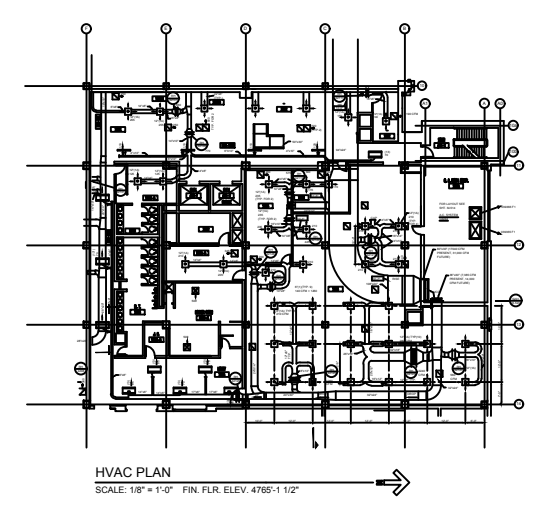

SYSTEMS ENGINEERING LTD.  
P.O. BOX 3891  
SEA COWS BAY  
TORTOLA, VG 1110, B.V.I.  
TEL: 284.494.2987  
FAX: 284.494.0775  
EMAIL: sytmeng@systemscuribbean.com

NOTES

01	DO NOT USE THIS DRAWING FOR CONSTRUCTION UNLESS THE WORDS "CONSTRUCTION SET" APPEARS IN THE REVISIONS COLUMN
02	

ANEGADA FIRE STATION METAL  
BUILDING :  
THE SETTLEMENT  
ANEGADA  
BVI  
**FOR CONSTRUCTION**

01	PRELIM. ISSUE TO ARCH.	MT	25 10 13
A	PRELIM. ISSUE TO ARCH.	MT	25 10 13
REV #	DESCRIPTION	DWN	YYMMDD

ISSUE INFORMATION:	01
DESIGNER:	RT
DRAWN:	BM
JOB REF:	
DATE:	25 10 13
SCALE:	AS NOTED
DWG NAME:	<b>ELEVATIONS</b>

DWG NO:  
**S-201**  
VERS. 3.0 - 071219

